

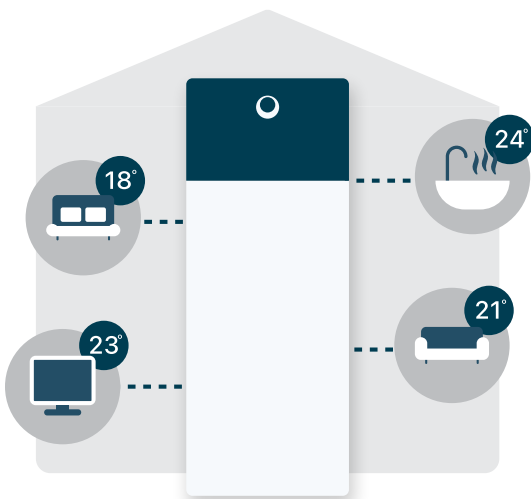

Application Guide

Daikin Home Controls



EKRACPUR1PA
EKRACPUR1PU
EKRCTRD12BA
EKRCTRD13BA
EKRMIBEV1V3
EKRRVATR2BA
EKRRVATU1BA
EKRENDI1BA
EKRSIBD1V3
EKRUFT61V3
EKRK

Table of contents

1	Daikin Home Controls	4
1.1	About Daikin Home Controls (DHC).....	4
1.1.1	Room-by-room control.....	4
1.1.2	Schedules.....	4
1.1.3	Cloud connection.....	5
1.2	About DHC wireless communication.....	5
1.3	About DHC accessories.....	6
1.4	About supported devices.....	10
2	Initial setup	14
2.1	DHC Access Point setup.....	14
2.1.1	To add a DHC Access Point to the ONECTA app.....	14
2.2	IO Box.....	21
2.2.1	To add an IO Box to the ONECTA app.....	22
2.3	Other DHC accessories.....	28
2.3.1	To add DHC accessories to the ONECTA app.....	29
2.3.2	Room creation and assignment.....	34
2.4	DHC Floor Heating Controller.....	38
2.4.1	To add a DHC Floor Heating Controller to the ONECTA app.....	38
2.5	Setup test.....	47
3	Applications	48
3.1	Single zone.....	48
3.1.1	Single zone heating only.....	48
3.1.2	Single zone heating/cooling.....	49
3.1.3	Single zone to dual zone.....	49
3.1.4	Special application: Single zone reversible with dehumidifier.....	50
3.1.5	Special application: Single zone reversible without dehumidifier.....	53
3.2	Bizone.....	54
3.2.1	Bizone heating only.....	54
3.2.2	Bizone heating/cooling.....	54
3.2.3	Bizone heating only with room thermostat (Human Comfort Interface).....	55
3.2.4	Bizone reversible with room thermostat (Human Comfort Interface).....	55
3.2.5	Special application: Bizone heating/cooling with dehumidifier.....	56
4	Connections to the Daikin Altherma unit	58
5	Compatibility	59
6	Daikin Altherma user interface settings	61
6.1	Settings for single zone.....	61
6.2	Settings for bizone.....	62
6.3	Settings for special applications.....	65
7	Firmware updates	67
8	Troubleshooting	68
8.1	Resetting to factory settings.....	68
8.1.1	To reset and delete the entire installation.....	68
8.1.2	To reset the DHC Access Point.....	68
8.1.3	To reset the DHC Radiator Thermostat.....	69
8.1.4	To reset the DHC Radiator Thermostat (UK).....	69
8.1.5	To reset the DHC Room Sensor.....	69
8.1.6	To reset the DHC Room Thermostat — 1.....	69
8.1.7	To reset the DHC Room Thermostat — 2.....	69
8.1.8	To reset the DHC Basic IO Box.....	70
8.1.9	To reset the DHC Floor Heating Controller — 6 zones.....	70
8.1.10	To reset the DHC Multi IO Box.....	70
8.2	Unreachable accessories.....	70
9	Wiring diagram	72
9.1	DHC Basic IO Box.....	72
9.2	DHC Multi IO Box.....	73
9.3	DHC Multi IO Box with EKRK.....	75
10	Appendix	78
10.1	Guidelines when installing a DHC Floor Heating Controller.....	78

10.1.1	Basic requirements	78
10.1.2	About multi-zoning	78
10.1.3	About the use of a DHC Floor Heating Controller	80
10.1.4	Technical specifications	80
10.2	About non-connected solutions.....	81
10.2.1	Single temperature water zone heating only unit with underfloor heating	81
10.2.2	Bizone unit with two independent water zones	84
10.3	Configuration	86
10.3.1	DHC Room Thermostat — 1	86
10.3.2	DHC Room Thermostat — 2	90
10.3.3	DHC Floor Heating Controller	96
10.4	Manual operation	96
10.4.1	DHC Room Thermostat — 1	96
10.4.2	DHC Room Thermostat — 2	96
10.4.3	DHC Floor Heating Controller	97
10.5	Loss of internet connectivity when using DHC Radiator Thermostat	97

1 Daikin Home Controls

1.1 About Daikin Home Controls (DHC)

Daikin Home Controls is a selection of accessories that extends the capabilities of your Daikin Altherma unit to offer demand-based and room-by-room control of heating (and cooling if your Daikin Altherma unit supports it) in the entire house, enabling increased living comfort.

The regulation of heating or cooling can be controlled via the DHC Floor Heating Controller or the DHC Radiator Thermostats.

The system interacts with your Daikin Altherma unit via a DHC Multi IO Box (for reversible units) or a DHC Basic IO Box (for heating only units). Either IO Box accessory is the only DHC accessory that is mandatory in order to connect Daikin Altherma units to the DHC ecosystem. For more information about setting up the hydraulic connections and application examples, see the installer reference guide of your Daikin Altherma unit.

The DHC accessories can communicate with each other through a wireless protocol. The DHC Access Point provides access to the ONECTA cloud and delivers an intuitive configuration of the system through the ONECTA app, offering heating/cooling schedules per room as well. The room temperature can be monitored via the ONECTA app using one of the DHC Room Thermostats, DHC Radiator Thermostats, or a DHC Room Sensor.

Your heating is controlled automatically and makes the everyday life easier. However, you can still react flexibly to changed conditions and adjust the desired temperature according to your needs.

1.1.1 Room-by-room control

In order to set up the control for a room, the following is required:

- The room **MUST** have a DHC controlled emitter:
 - A DHC Radiator Thermostat on a radiator,
 - A DHC Floor Heating Controller in combination with underfloor heating, or
 - A Homematic IP pluggable switch and meter, which integrates an electric heating device.
- The room **MUST** have a DHC accessory that can measure the temperature (in case of underfloor heating):
 - a DHC Room Thermostat, or
 - a DHC Room Sensor

Please note that a DHC Room Thermostat is **NOT** mandatory in case of radiators with a DHC Radiator Thermostat, as the DHC Radiator Thermostat can measure the temperature by itself. Adding a DHC Room Thermostat will however improve your comfort, because you can choose the location where the temperature is being measured. Via the ONECTA app, both accessories will be added to the room and the DHC Radiator Thermostat will follow the temperature measurements of the DHC Room Thermostat.

1.1.2 Schedules

In the ONECTA app, you can create and manage a house (max. 5) with a maximum of 25 rooms and up to 40 DHC accessories. For each room, a total of 6 schedules can be set:

- 3 for heating (activated when the Daikin Altherma unit is in heating mode)
- 3 for cooling (activated when the Daikin Altherma unit is in cooling mode)

Each schedule allows a maximum of 6 time slots per day. A time slot can be set by choosing a start time, a stop time and a setpoint.

Schedules in the DHC ecosystem behave differently than the scheduling function that the Daikin Altherma unit offers. When a schedule is set in the ONECTA app, the system will aim to reach the desired temperature by activating heating/cooling in order to reach the desired setpoint by the scheduled time. DHC aims to optimise when it should try and reach the desired setpoint, taking into account how the DHC setup has managed to reach the desired setpoint the days before. On the other hand, a schedule set on the Daikin Altherma unit (without using DHC) only starts to attempt to reach the desired setpoint at the scheduled time.



INFORMATION

Holiday mode can be activated in the ONECTA app to deviate from your normal schedules without having to change them. While holiday mode is active, space heating/cooling will be turned OFF and your system will be put in standby.

1.1.3 Cloud connection

The cloud connection operates as a bridge between the DHC Access Point and the other DHC accessories. It allows the ONECTA app to configure and manage the different DHC accessories and devices in your ONECTA system.

In case of an interruption of the connection to the ONECTA cloud, the ONECTA app will NOT be able to manage your DHC accessories and devices, but the direct wireless link between the DHC accessories guarantees the correct heating or cooling operation.

1.2 About DHC wireless communication

The DHC wireless communication is based on the 868 MHz radio band. There is no interference from WLAN, Bluetooth, video streaming or other users of 2.4 GHz and 5 GHz.



NOTICE

To avoid radio interference between different DHC accessories, it is recommended to keep a minimum distance of 50 cm between WLAN routers and the DHC accessories, as well as between the DHC accessories themselves.

Wireless range

Depending on the device type, a wireless range between 150 and 400 meters in the open air can be reached. The signal strength will vary, depending on how many obstacles are between the devices. ALWAYS avoid putting wireless devices inside metal enclosures or close to other wireless devices. Use the RF analyser to detect range issues. For more information, see "[8.2 Unreachable accessories](#)" [▶ 70].

Unreachable devices

Devices can become unreachable for different reasons:

- Poor signal strength (you can add a HmIP-PSM to resolve this, see "[8.2 Unreachable accessories](#)" [▶ 70]),
- Low battery, or
- Duty cycle limit was reached (see Duty cycle).

If possible, the ONECTA app will provide a notification that explains why a device is unreachable.



INFORMATION

It is recommended to keep accessories nearby the DHC Access Point when adding them in the ONECTA app.

RF analyser

To check the radio environment of your DHC accessories, you can use the EQ3-RFA radio analyser. By analysing the transmitting and receiving power of the used DHC accessories, you can better decide where to place the individual accessories for optimal results.

In case of issues, contact Daikin Service Centre.

Duty cycle

The wireless DHC accessories operate in the following frequency bands:

- 868.000~868.600 MHz
- 869.400~869.650 MHz

In order to safeguard operation of all devices working in this range, it is legally required to limit the transmission time of devices. Limiting the transmission time minimises the risk of interference.

The 'duty cycle' is the maximum transmission time. It is the ratio of the time that a device is actively transmitting in comparison to the measurement period (1 hour), and is expressed as a percentage of 1 hour.

If the total amount of allowed transmission time is reached, the DHC accessory will stop transmitting until the time limit is reached.

For example, when a device has a duty cycle limit of 1%, it is ONLY allowed to transmit 36 seconds in 1 hour. After this, it will stop transmitting until the 1 hour limit is reached.

DHC accessories fully comply to this limitation and use 2 frequency bands with a duty cycle of respectively 1% and 10%.

During normal operation of the DHC accessories, this limit is NOT usually reached. However it is possible that the limit is reached during start-up or during a fresh installation of a system. In this case, the LED of the accessory lights up red. It may be non-responsive for a short period (max. 1 hour), until the time restriction for transmission has expired. After this period, it will operate normal again.

1.3 About DHC accessories

The DHC ecosystem contains 12 accessories. The table below gives a complete overview of those accessories.

Daikin reference	Full model description
EKRACPUR1PA	DHC Access Point
EKRACPUR1PU	DHC Access Point (UK)
EKRACPUR2PA	DHC Access Point 2
EKRACPUR2PU	DHC Access Point 2 (UK)
EKRCTRD12BA	DHC Room Thermostat — 1
EKRCTRD13BA	DHC Room Thermostat — 2

Daikin reference	Full model description
EKRMIBEV1V3	DHC Multi IO Box
EKRRVATR2BA	DHC Radiator Thermostat
EKRRVATU1BA	DHC Radiator Thermostat (UK)
EKRSENDI1BA	DHC Room Sensor
EKRSIBDI1V3	DHC Basic IO Box
EKRUFHT61V3	DHC Floor Heating Controller — 6 zones



INFORMATION

To integrate any DHC accessories into the DHC ecosystem, either the DHC Basic IO Box or the DHC Multi IO Box is required. Other DHC accessories are optional.

While the DHC Access Point is strongly recommended to more easily configure and monitor accessories via the ONECTA app, it is NOT strictly required. Note that the possible applications of a setup without a DHC Access Point are more limited and situational. In this case, the applications described in "3 Applications" [▶ 48] are NOT possible. For more information, see "10.2 About non-connected solutions" [▶ 81].

DHC Access Point

The DHC Access Point connects the ONECTA app on your smartphone via the ONECTA cloud with all DHC accessories. It transmits configuration and operating commands from the ONECTA app to the DHC accessories.



INFORMATION

The design of DHC Access Point devices is different, but their functionality is the same.



1-1 DHC Access Point & DHC Access Point (UK)



1-2 DHC Access Point 2 & DHC Access Point 2 (UK)

DHC Room Thermostat — 1 & DHC Room Thermostat — 2

The DHC Room Thermostat measures the temperature and relative humidity in the room. It also enables time-controlled regulation of your conventional radiators with DHC Radiator Thermostats, or of your underfloor heating in combination with DHC Floor Heating Controllers, and adjusts heating time slots to your individual needs.



1-3 DHC Room Thermostat — 1



1-4 DHC Room Thermostat — 2

DHC Multi IO Box

The DHC Multi IO Box connects your Daikin Altherma unit to the DHC ecosystem. The accessory allows comfortable and demand-based regulation of the room temperature for both heating and cooling according to your personal needs, provided that your Daikin Altherma unit supports it.



1-5 DHC Multi IO Box

DHC Radiator Thermostat

The DHC Radiator Thermostat enables time-controlled regulation of the room temperature via a heating schedule with individual time slots. For precise regulation of the room temperature, the DHC Room Thermostat can measure the

actual temperature of a room and transmit the data to the DHC Radiator Thermostat.

The DHC Radiator Thermostat is compatible with M30×15 connections, adapters are included in the box. To support M28 connections, an additional eQ-3 adapter (part number 76030A1B) is needed, which is sold separately.



1-6 DHC Radiator Thermostat

DHC Radiator Thermostat (UK)

The DHC Radiator Thermostat enables time-controlled regulation of the room temperature via a heating schedule with individual time slots. You can create 3 different schedules with up to 6 time slots per day.

This way, the Radiator Thermostat is able to regulate the setpoint on room level. When the setpoint for a room is higher than the current room temperature, the Radiator Thermostat signals the demand for heating to the IO Box, which in turn drives the heat demand on the Daikin Altherma unit;



1-7 DHC Radiator Thermostat (UK)

DHC Room Sensor

The DHC Room Sensor measures the room temperature and humidity and transmits these values at intervals to the DHC Access Point as well as to the ONECTA app, enabling to regulate the room climate according to your needs.



1–8 DHC Room Thermostat

DHC Basic IO Box

The DHC Basic IO Box connects your Daikin Altherma unit to the DHC ecosystem. The accessory allows comfortable and demand-based regulation of the room temperature for heating according to your personal needs.



1–9 DHC Basic IO Box

DHC Floor Heating Controller — 6 zones

The DHC Floor Heating Controller offers comfortable and demand-based room-by-room control of your floor heating system, according to your personal needs, via the ONECTA app in combination with a DHC Access Point.

For more information and installation guidelines, see "[10.1 Guidelines when installing a DHC Floor Heating Controller](#)" [▶ 78].



1–10 DHC Floor Heating Controller

1.4 About supported devices

There are a number of devices from Homematic IP that can be integrated into the DHC ecosystem. The following table gives an overview of those devices.

Reference	Full model description
HmIP-PSM HmIP-PSM-2 HmIP-PSM-2-QHJ	Pluggable switch and meter
HmIP-PSM-PE HmIP-PSM-PE-2	Pluggable switch and meter (Pin-Earth)
HmIP-PSM-UK	Pluggable switch and meter (UK)
HmIP-PSM-IT	Pluggable switch and meter (IT)
HmIP-PSM-CH HmIP-PSM-CH-2	Pluggable switch and meter (CH)
HmIP-SWDO	Window and door contact — optical
HmIP-SWDO-I HmIP-SWDO-A	Window and door contact — invisible installation
HmIP-SWDO-PL HmIP-SWDO-PL-2	Window and door contact — optical, plus
HmIP-SWDM HmIP-SWDM-2	Window and door contact with magnet

Pluggable switch and meter

The Homematic IP pluggable switch and meter can be used for various purposes. The ONECTA app supports the following functionalities:

- Emitter control: Integrate an electric heating device which, in combination with a room thermostat, can be controlled and scheduled by your ONECTA system.
- Switch control: Enable devices with an on/off switch in the ONECTA app.
- Power metering: Accurately measure power consumption.
- RF range extender: Resolve problems with unreachable devices.



1-11 Pluggable switch and meter



1-12 Pluggable switch and meter (Pin-Earth)



1-13 Pluggable switch and meter (UK)



1-14 Pluggable switch and meter (IT)



1-15 Pluggable switch and meter (CH)

Window and door contact

The window and door contact enables the system to respond to an open door or window by adjusting the desired room temperature.



1-16 Window and door contact — optical



1-17 Window and door contact — invisible installation



1-18 Window and door contact — optical, plus



1-19 Window and door contact with magnet

2 Initial setup

To start using the DHC ecosystem, set up the DHC Access Point first. Once the setup has been completed, other DHC accessories can easily be added.

The DHC Access Point provides access to the internet. Other DHC accessories will be connected to the DHC Access Point, which means they can be fully managed via the ONECTA app. This is the recommended way to use DHC accessories.



INFORMATION

ALWAYS keep a minimum distance of 50 cm between the accessories.

2.1 DHC Access Point setup

When first setting up the DHC Access Point, make sure that:

- the DHC Access Point is connected to a power source using the plug-in mains adapter,
- the DHC Access Point is connected to the router via Ethernet cable.

When the DHC Access Point detects an active Internet connection, it will try to update its firmware to the latest available version. The LED will cycle through various colours until it eventually persists as a blue light. This indicates that the connection to the cloud has been established. The device can now be added in the ONECTA app.



INFORMATION

The procedure for setting up the DHC Access Point and the DHC Access Point 2 is identical. The only difference between the devices is the location of the LED on the device. For more information, see the installation and operation manual of the accessory.



EKRACPUR1PA / EKRACPUR1PU



EKRACPUR2PA / EKRACPUR2PU

2.1.1 To add a DHC Access Point to the ONECTA app

Prerequisite: The DHC Access Point is connected to the cloud (persistent blue LED).

- 1 Open the ONECTA app on your mobile device.
- 2 Tap + in the top right corner.

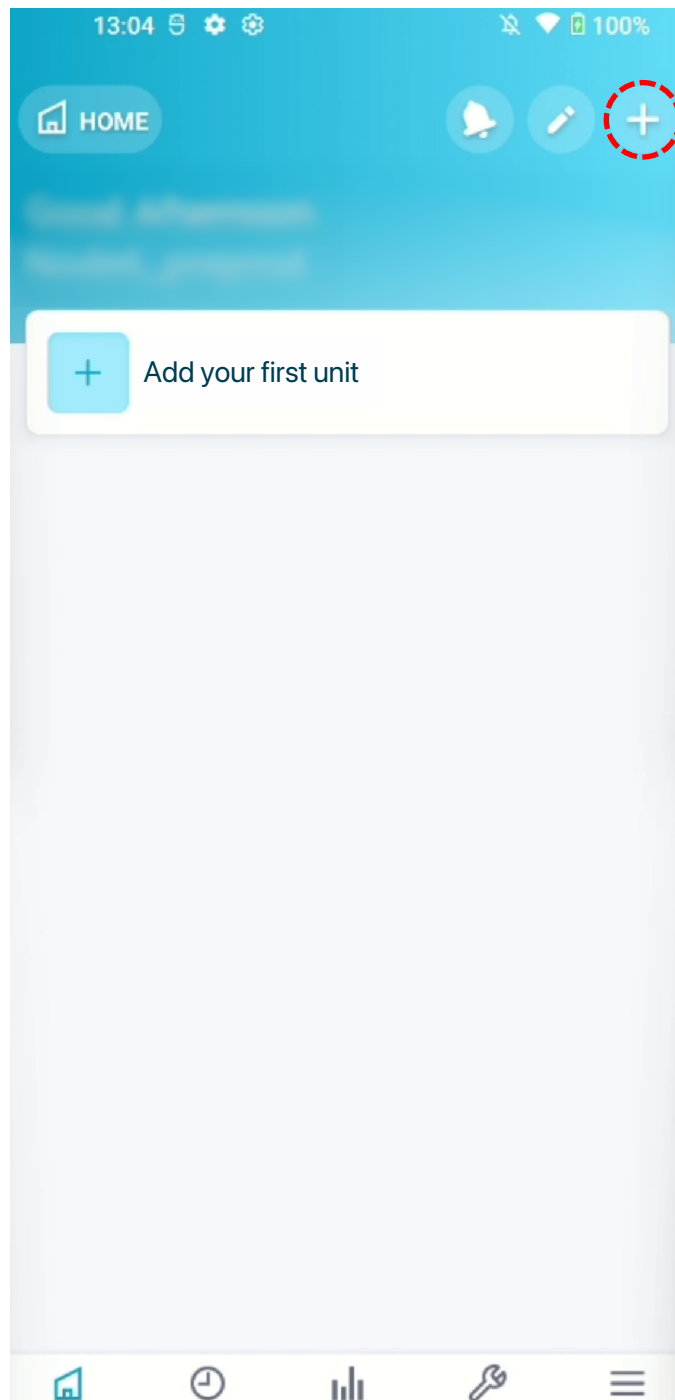

- 3 In the menu, select Add a device.

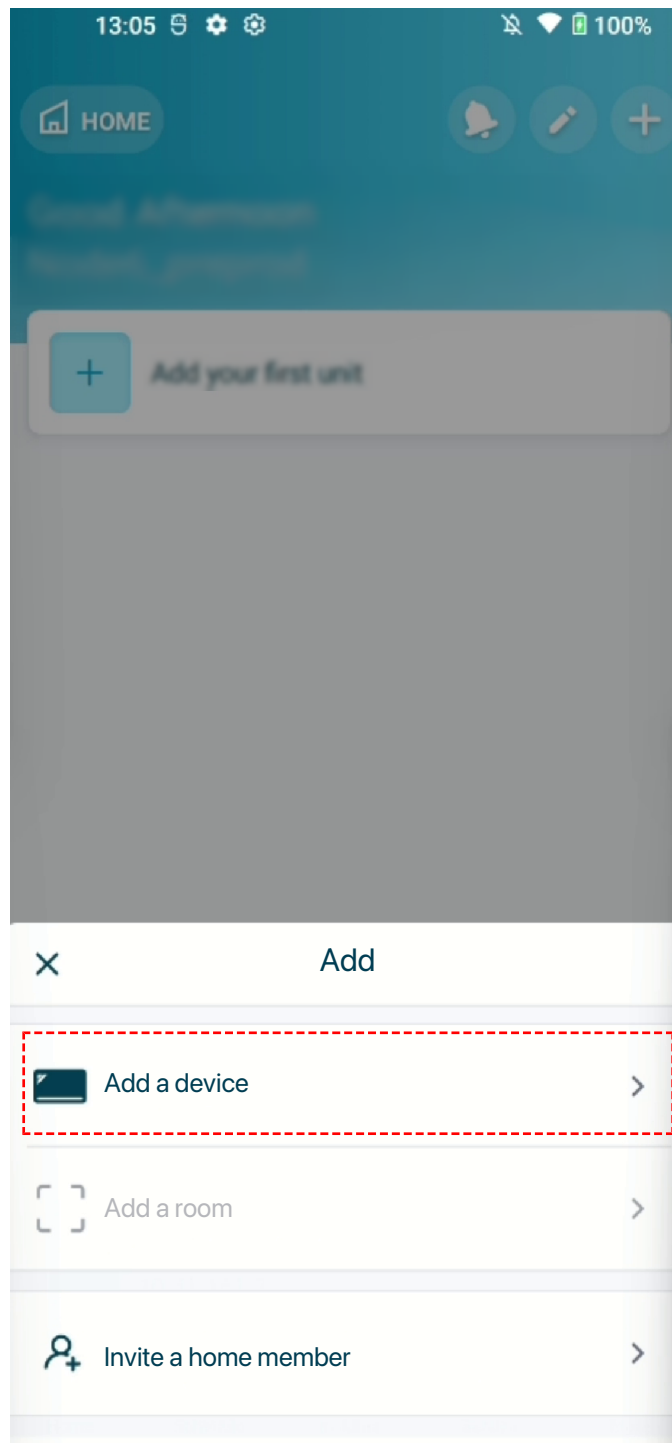

4 Select Daikin Home Controls.

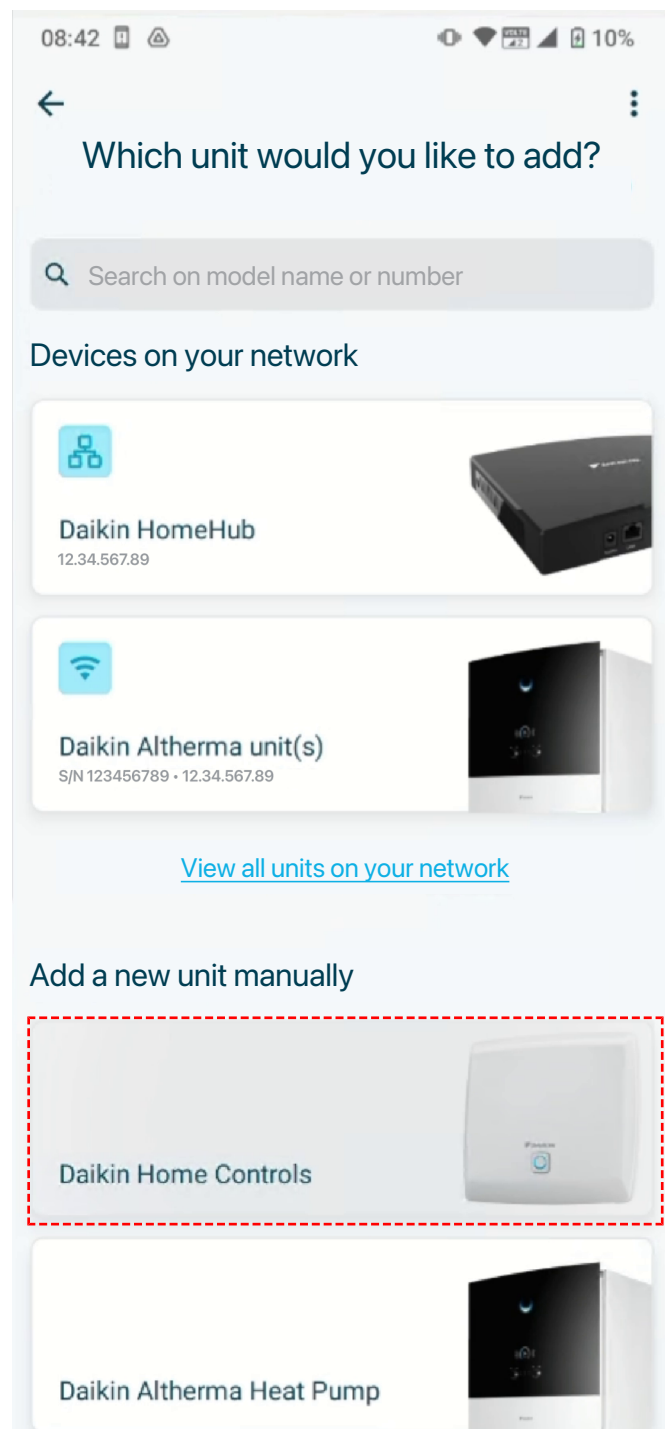

- 5 Select the Access Point you want to add.

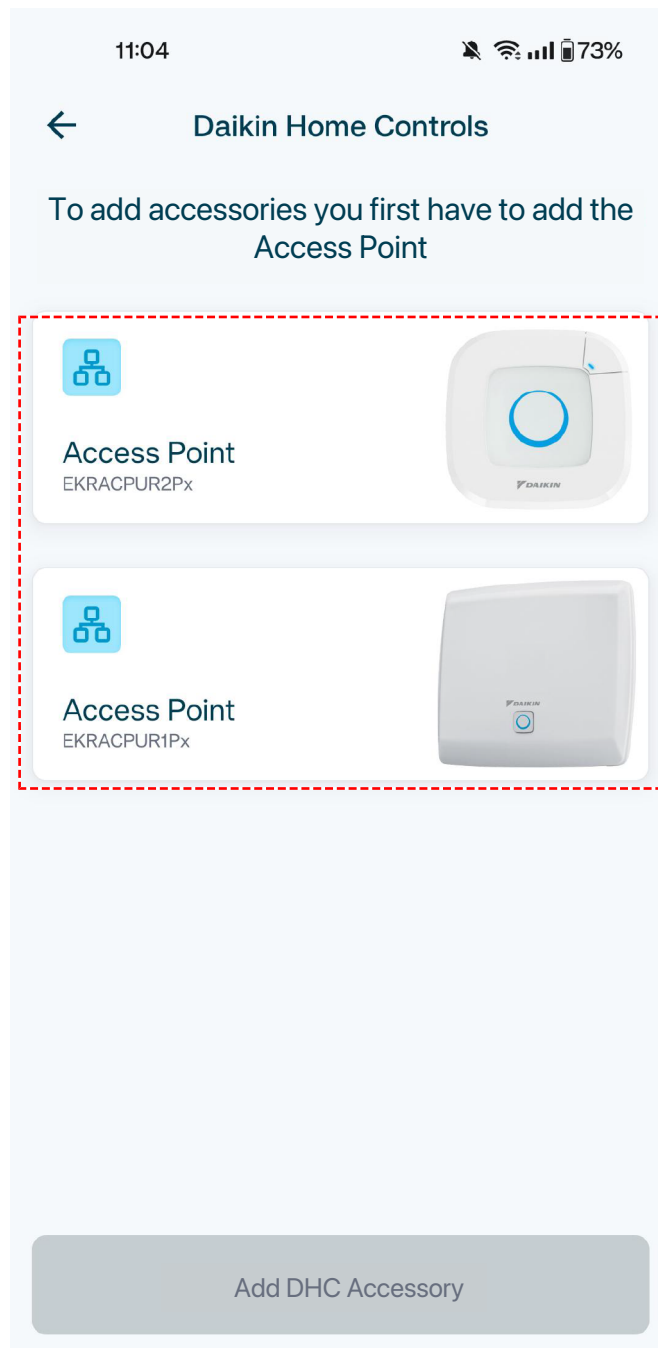

- 6 Enter the SGTIN code of the device. Alternatively, scan the QR code on the device.

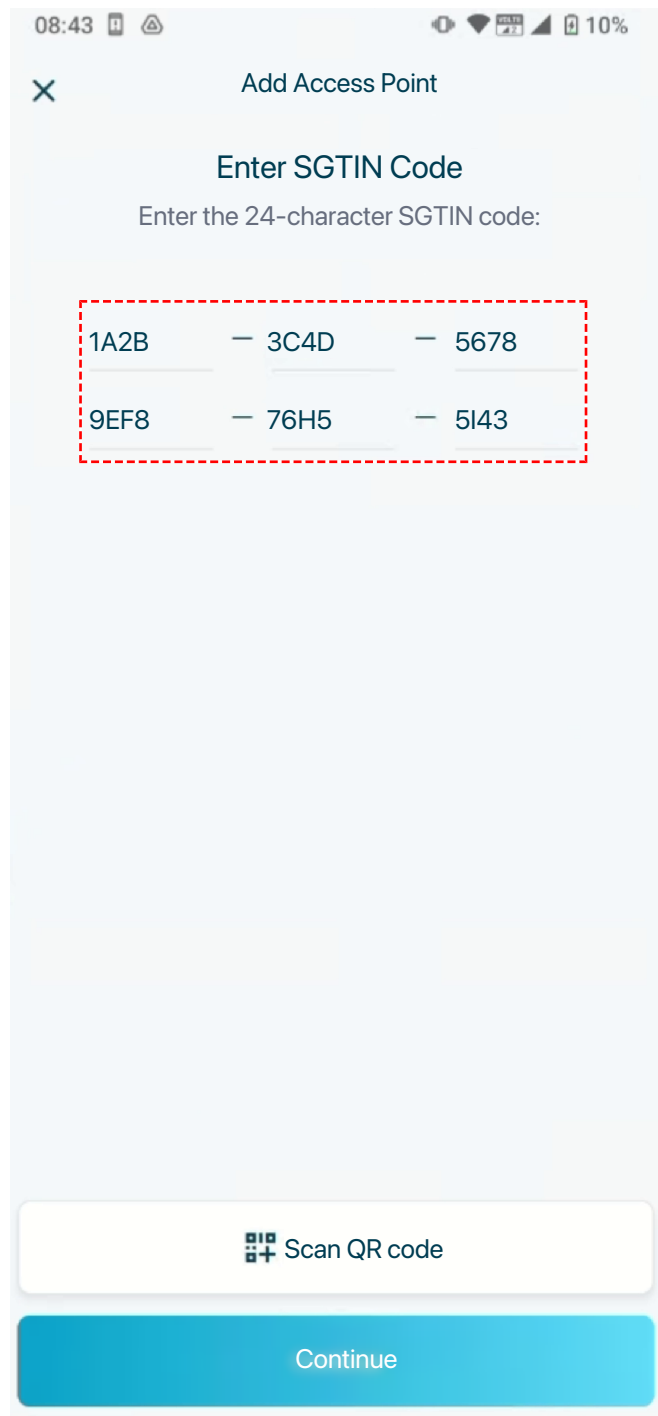

- 7** Press the button on the DHC Access Point to confirm the connection.
- 8** Assign the DHC Access Point to a Home.

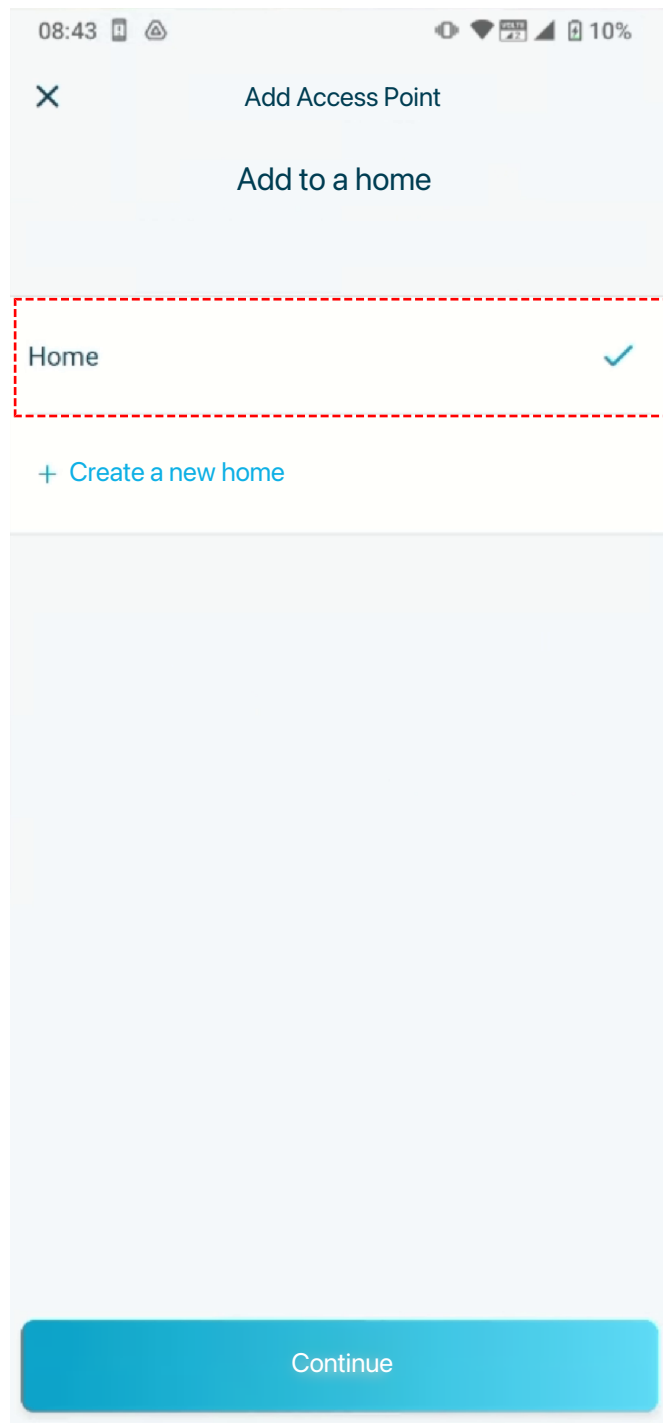

9 Set the time zone.

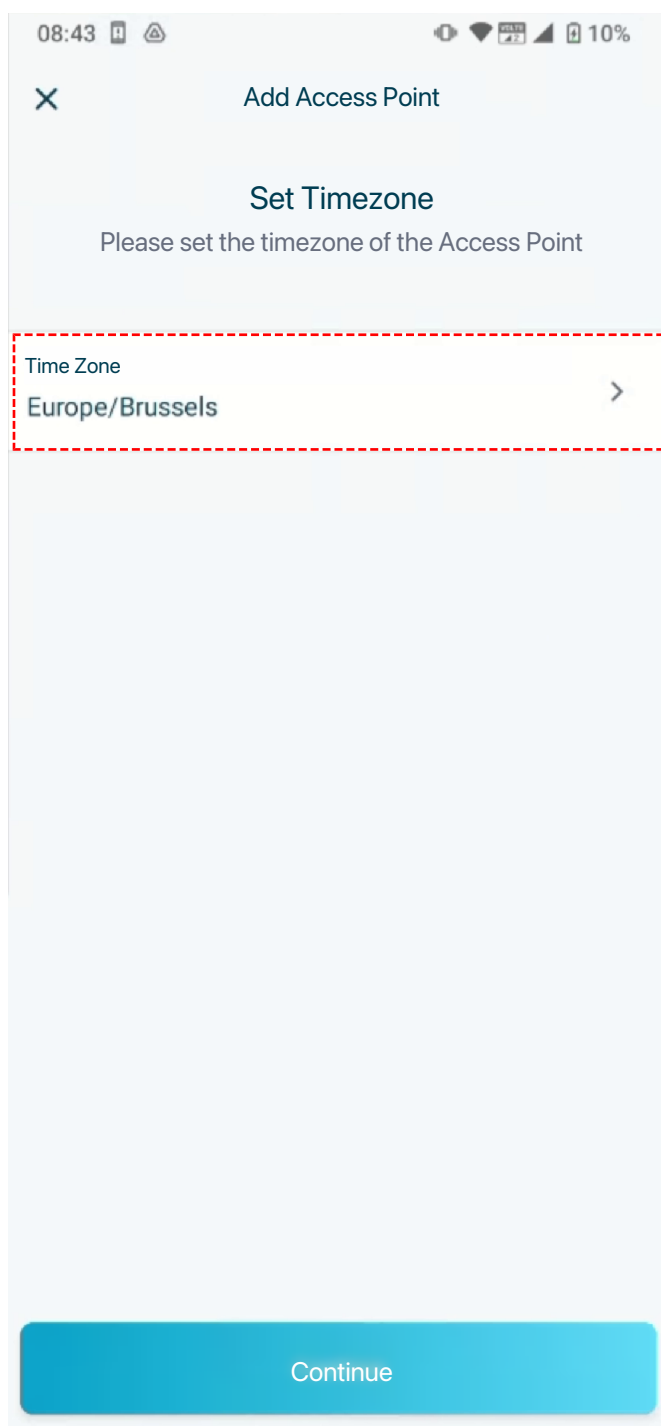

Result: The DHC Access Point is added to the ONECTA app. It is now possible to add other DHC accessories.

2.2 IO Box

When integrating a Daikin Altherma unit in the DHC ecosystem, an IO Box (DHC Multi IO Box or DHC Basic IO Box) is required to request the unit for heating/cooling demand for the main zone or the additional zone.

When connected to a reversible (heating/cooling) unit, the DHC Multi IO Box, the IO Box also sources the current operation mode of the Daikin Altherma unit, so that the DHC system can switch between heating and cooling.

In addition, there is a special application which requires additional connections. For more information, see ["3.1.4 Special application: Single zone reversible with dehumidifier"](#) [▶ 50].

During initial setup, the IO Box can already be connected to the Daikin Altherma unit. However, it is also possible to finish and test the setup and connect the IO Box to the Daikin Altherma unit later.

Zones	Heating/cooling	Connect to your Daikin Altherma unit via...
Single zone	Heating only	DHC Basic IO Box
	Heating/cooling	DHC Multi IO Box ^(a)
Bizone	Heating only	DHC Basic IO Box
	Heating/cooling	DHC Multi IO Box ^(a) <ul style="list-style-type: none"> ▪ Main zone can provide cooling via underfloor heating ▪ Additional zone can ONLY have thermostatic radiator valves. They do NOT support cooling.

^(a) For the DHC Multi IO Box to be able to read out the heating/cooling status signal of the Daikin Altherma, an extra relay [Normally open; Coil: 220~240VAC; non-corroding contacts (preferably gold-plated); minimum number of operations: 100.000] is required between the Daikin Altherma unit and the DHC Multi IO Box. This is because the Daikin Altherma unit provides a 230 V signal and the DHC Multi IO Box input ONLY accepts low voltage. The relay is included in the DHC Multi IO Box wiring diagrams. Note that the relay is not required for heating only units connected to a DHC Basic IO Box, since in this case no heating/cooling status signal is transmitted to the IO Box.

Note that the Daikin Altherma unit must be configured for the heating/cooling demand to be controlled via the Ext. RT contact. For more information about the user interface settings, see ["6 Daikin Altherma user interface settings"](#) [▶ 61]. For more information about how to connect the IO Box wiring to the Daikin Altherma unit, see ["9 Wiring diagram"](#) [▶ 72].

2.2.1 To add an IO Box to the ONECTA app

Prerequisite: The DHC Access Point has been set up and added to the ONECTA app. See ["2.1 DHC Access Point setup"](#) [▶ 14] for more information.

- 1 Open the ONECTA app on your mobile device.
- 2 Tap + in the top right corner.

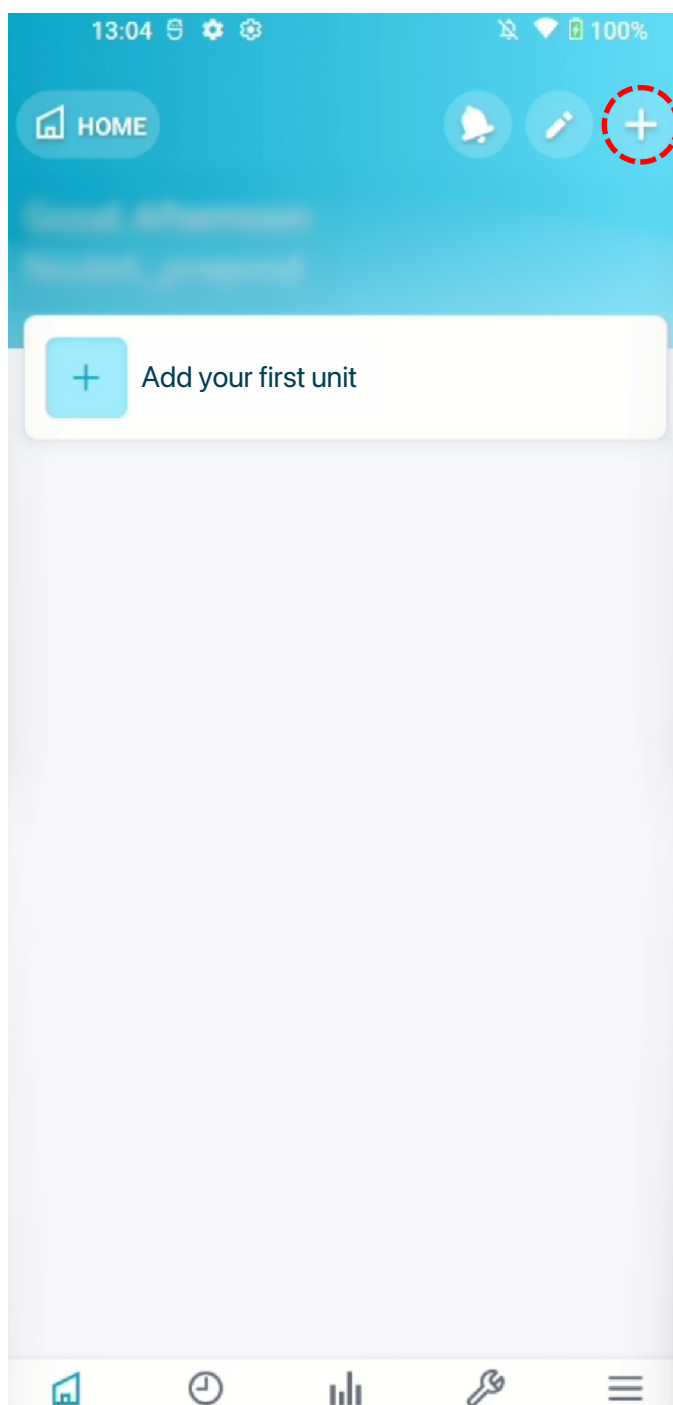

- 3 In the menu, select Add a device.

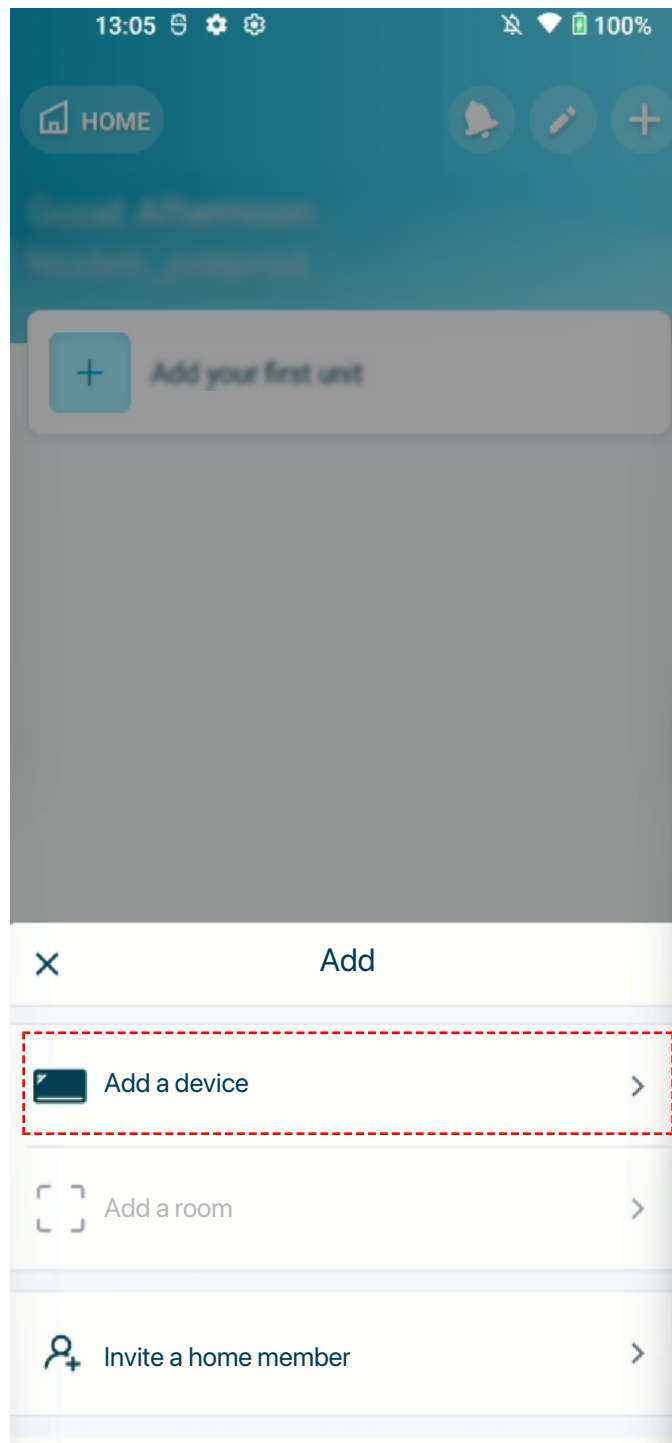

4 Select Daikin Home Controls.

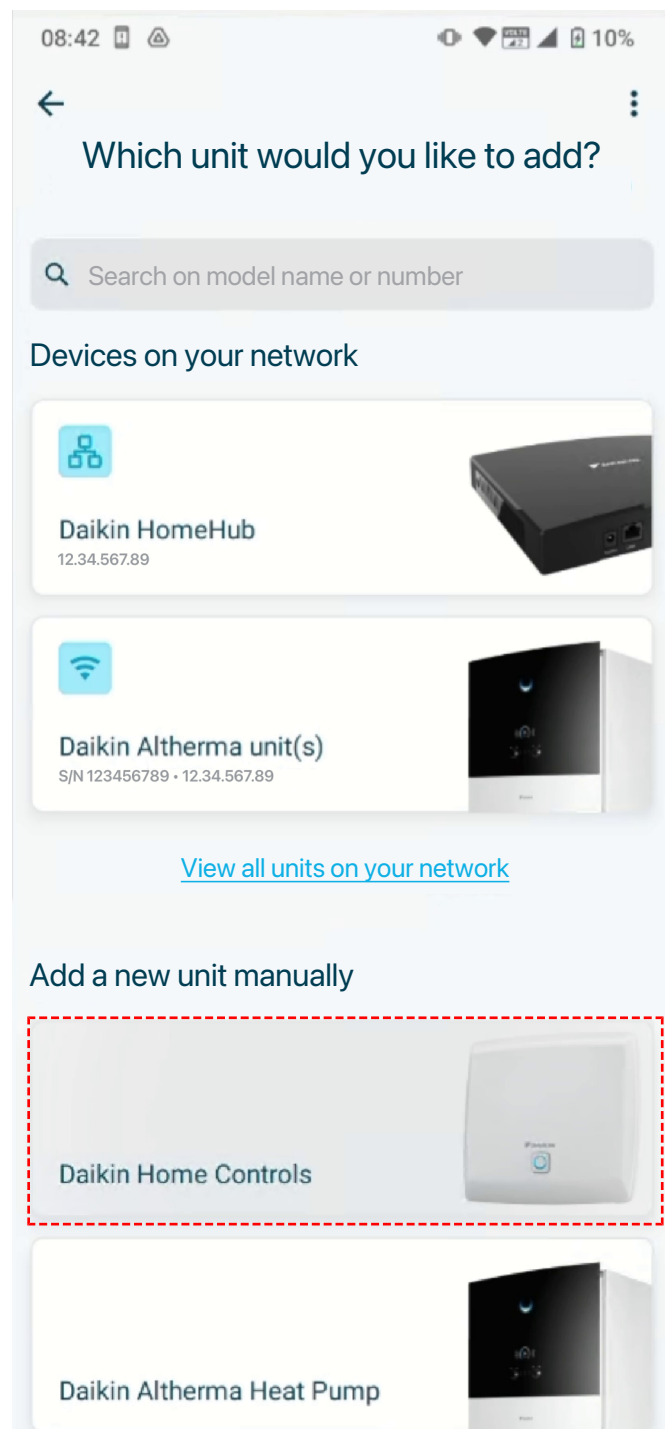

Result: The menu lists the previously connected DHC Access Point.

- 5 Briefly press the system button  on the IO Box to put the device in connection mode.
- 6 In the ONECTA app, select Add DHC Accessory.

Result: The DHC Access Point starts searching for devices that are ready to pair.

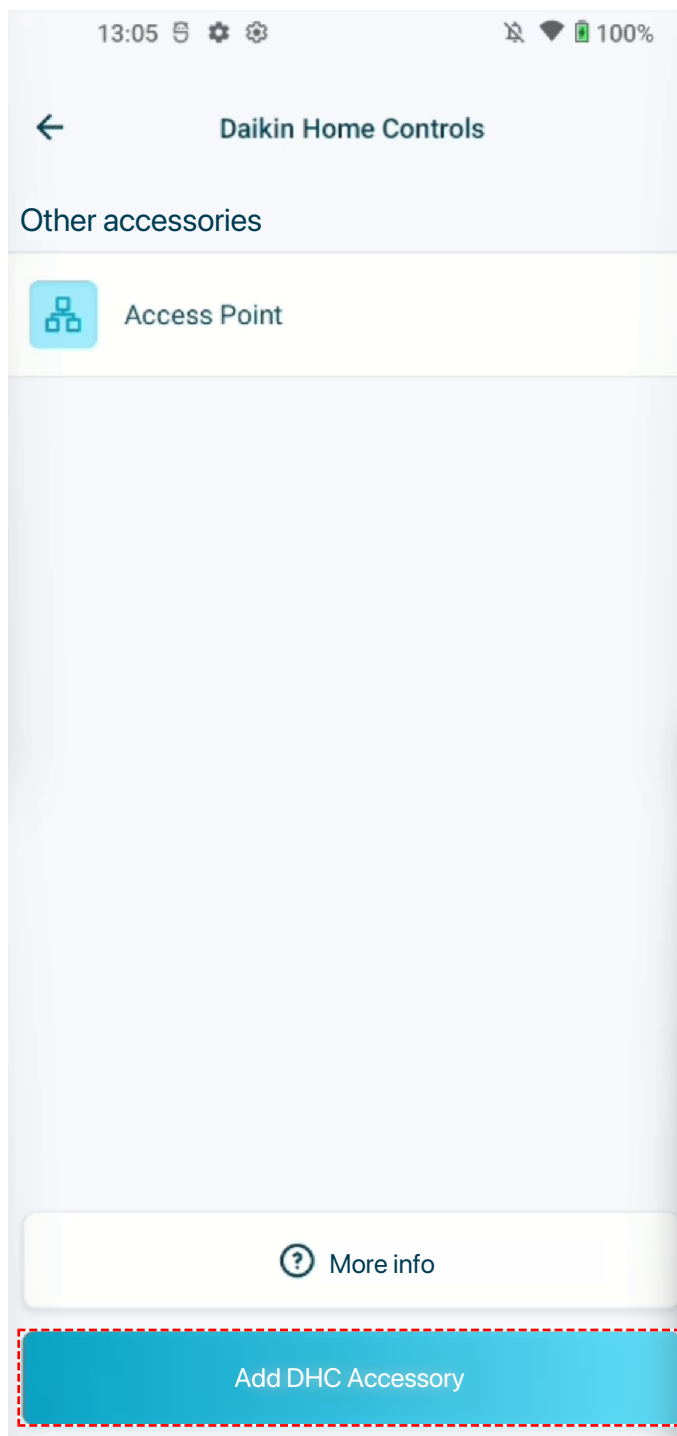

- 7 Enter the SGTIN code of the device. Alternatively, scan the QR code on the IO Box.

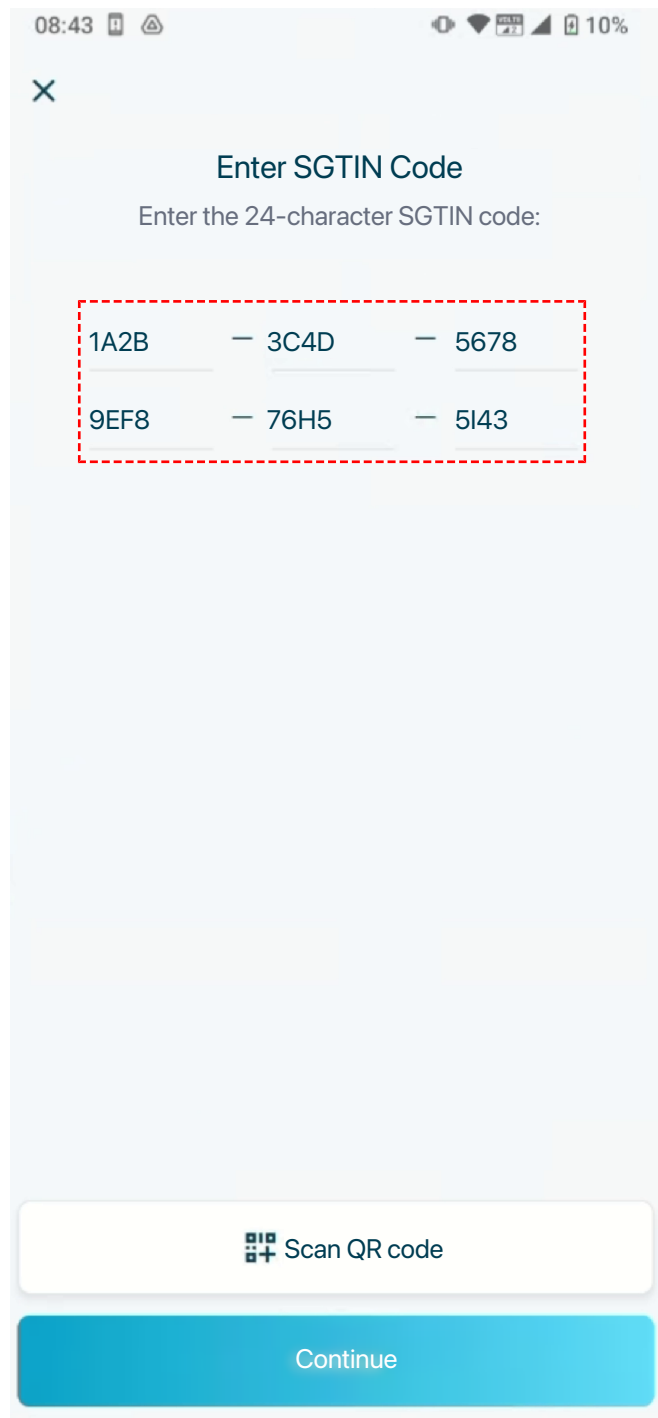

- 8 Wait for the connection to establish, then tap Close.



Result: The IO Box is added to the ONECTA app.

2.3 Other DHC accessories

At any point after the setup of the DHC Access Point, other DHC accessories can be added. Accessories require assignment to a room, except for the DHC Access Points and the DHC IO Boxes. The creation of rooms and the assignment of accessories to rooms is done using the ONECTA app. The procedure for connecting DHC accessories is generally the same, with the ONECTA guiding you through the required configuration steps.

2.3.1 To add DHC accessories to the ONECTA app

Prerequisite: The DHC Access Point has been set up and added to the ONECTA app. See "2.1 DHC Access Point setup" [▶ 14] for more information.

- 1 Open the ONECTA app on your mobile device.
- 2 Tap + in the top right corner.

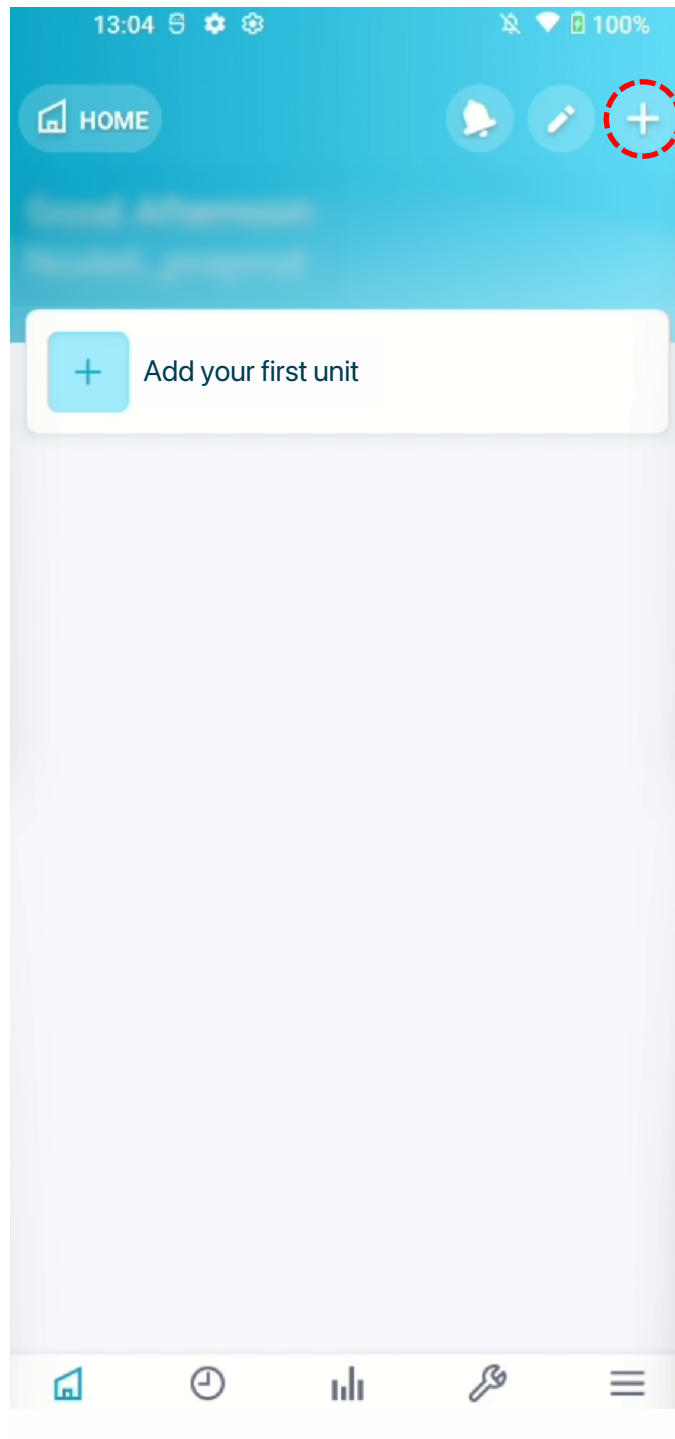

- 3 In the menu, select Add a device.

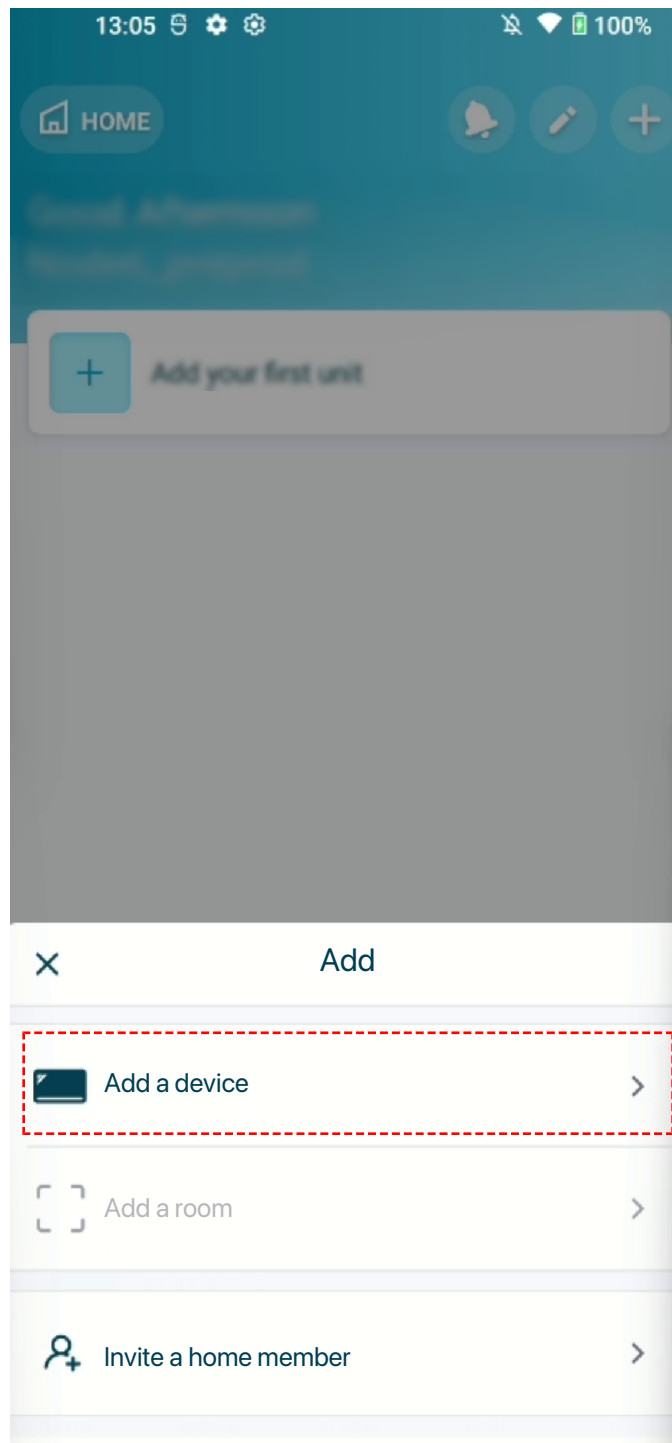

4 Select Daikin Home Controls.

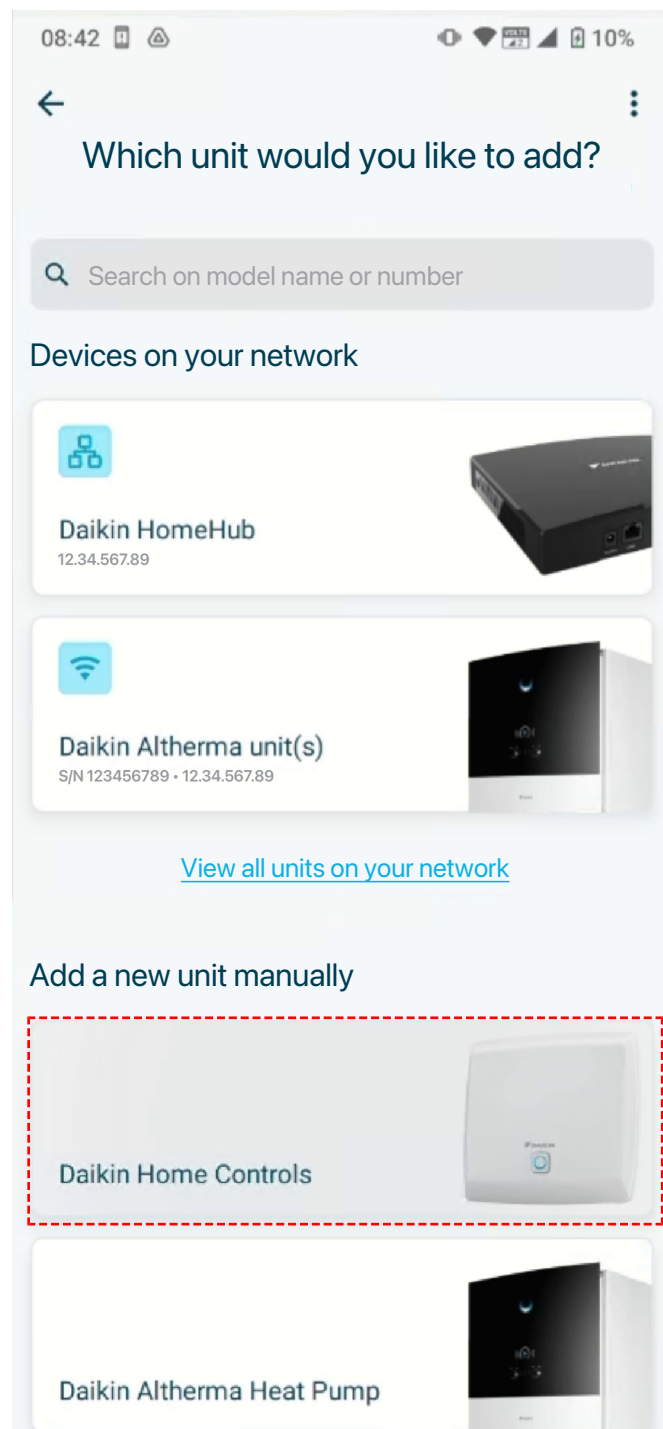

Result: The menu lists the previously connected DHC Access Point.

- 5 Briefly press the system button  on the accessory to put it in connection mode.
- 6 In the ONECTA app, select Add DHC Accessory.

Result: The DHC Access Point starts searching for devices that are ready to pair.

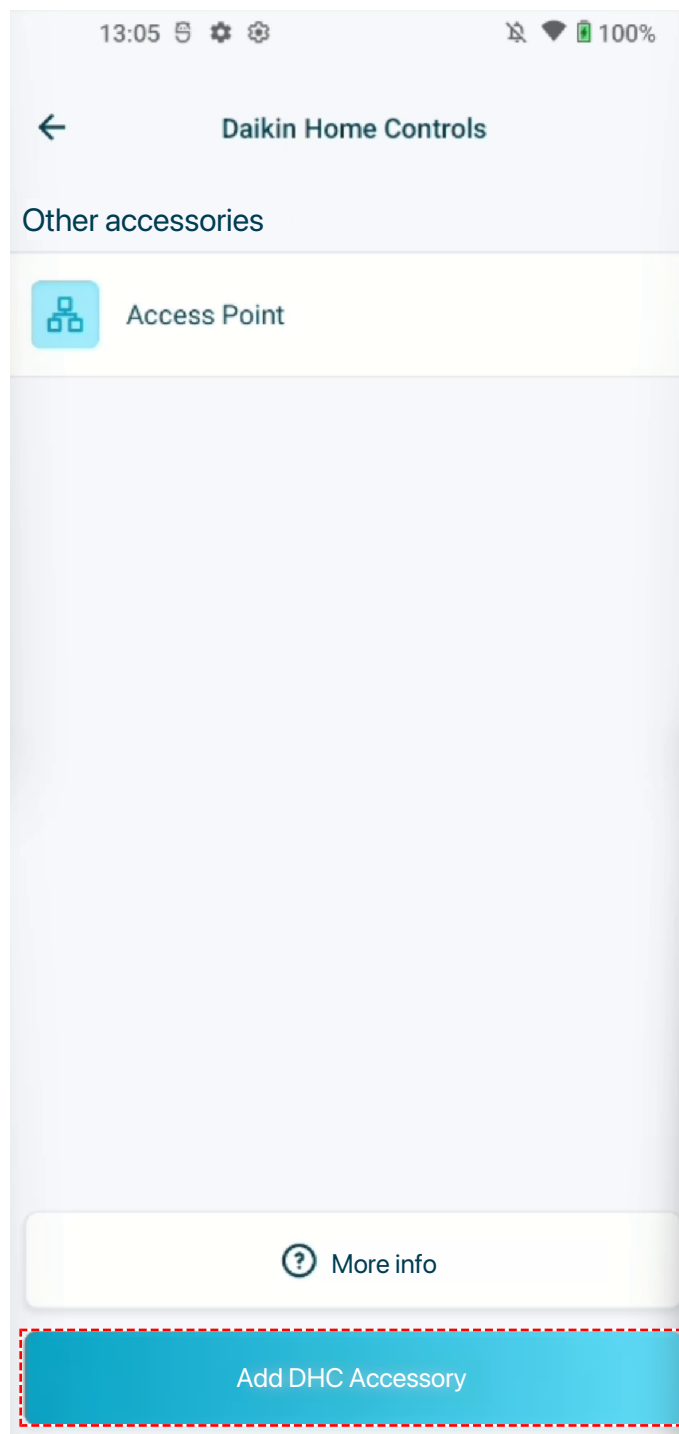

- 7 Verify that the correct accessory is displayed on screen. If the correct accessory is not displayed, exit out of the flow and restart the procedure from the beginning.
- 8 Enter the SGTIN code of the accessory. Alternatively, scan the QR code on or provided with the accessory.

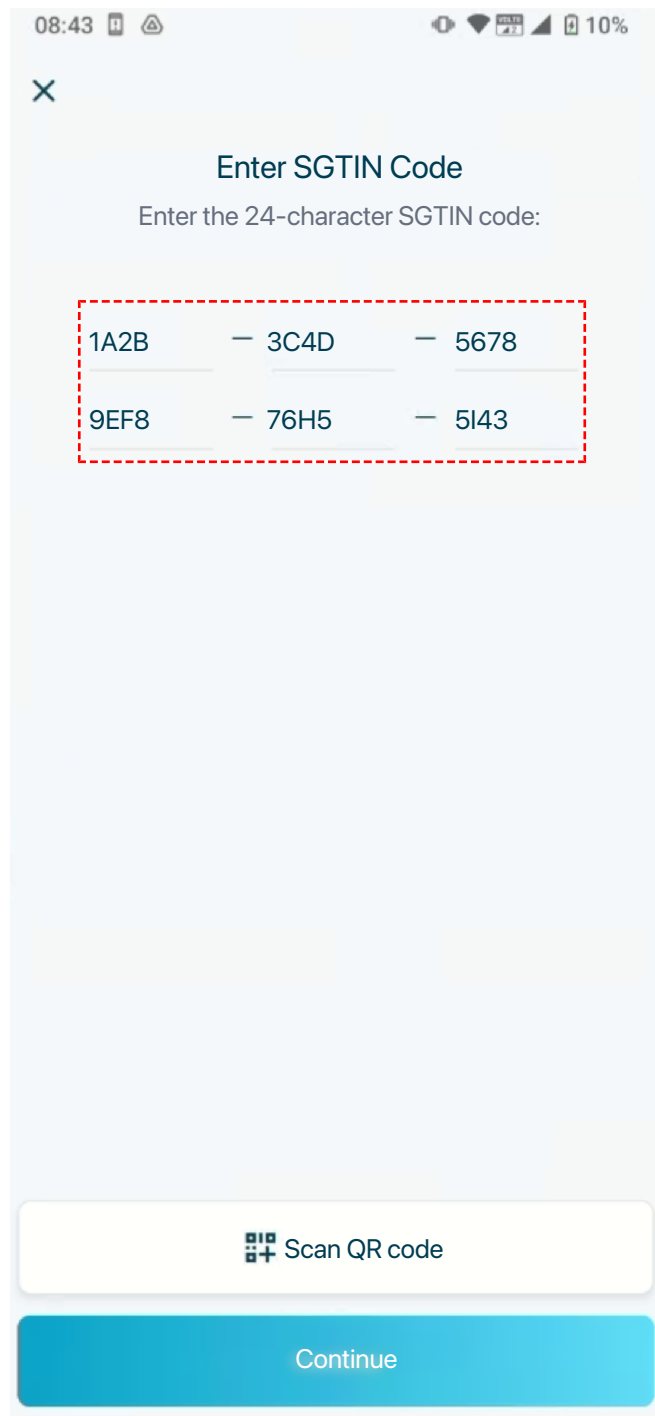

- 9 Name the accessory and assign it to a room. See ["2.3.2 Room creation and assignment"](#) [▶ 34] for more information. Then, tap Continue.

Result: The accessory is added to the ONECTA app. Once you have added an accessory, it is recommended to test the setup. See ["2.5 Setup test"](#) [▶ 47] for more information.

In case of DHC Radiator Thermostat

When adding a DHC Radiator Thermostat, the ONECTA app will request you to perform an adaptation run. In this case, press the menu button on the DHC Radiator Thermostat to start the adaptation run.



Once the adaptation run has finished, the DHC Radiator Thermostat is added to ONECTA as normal.

2.3.2 Room creation and assignment

Some accessories may require assignment to a room. If no room has been created before, it can be created when adding the accessories to the ONECTA app. All accessories except for DHC Access Points and DHC IO Boxes require assignment to a room.

Example: Adding a DHC Room Thermostat

- 1 Follow the instructions in "[2.3.1 To add DHC accessories to the ONECTA app](#)" [▶ 29] until you reach the room assignment screen.
- 2 Tap Create a new room.

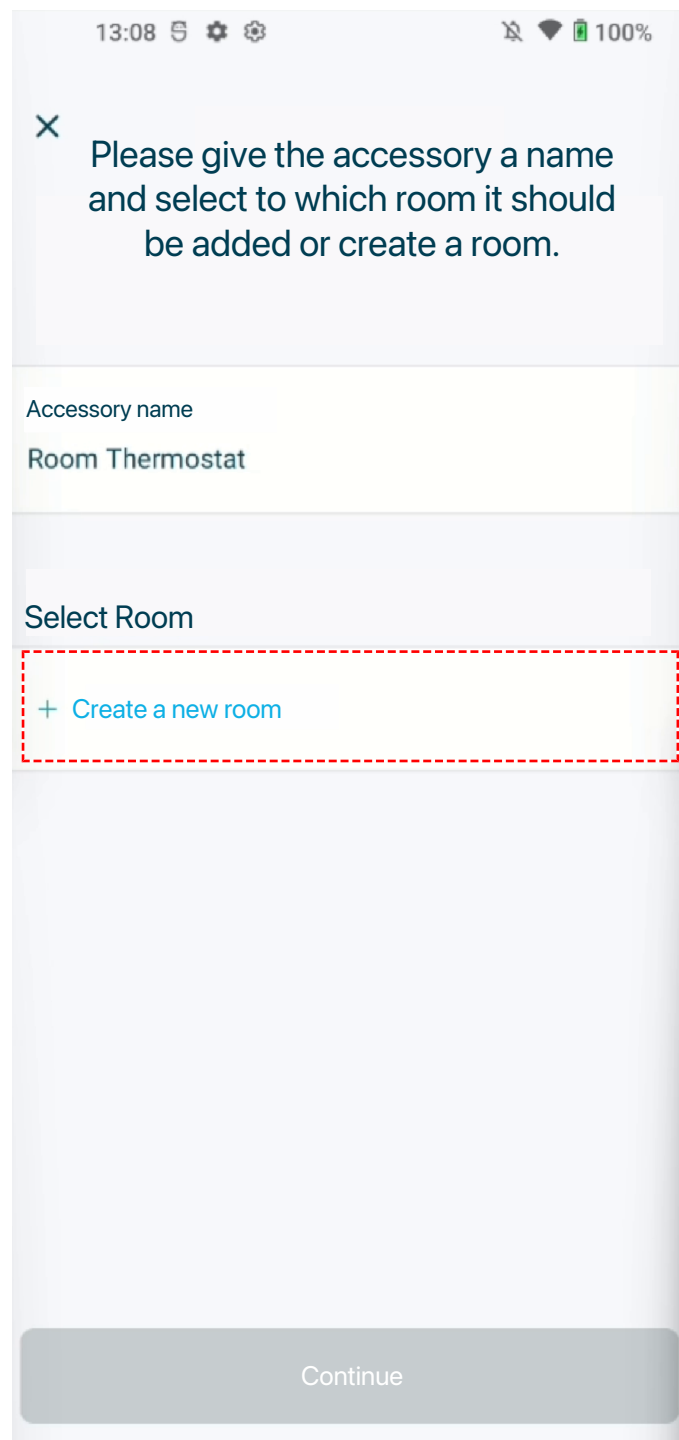

- 3 Name the room and select an icon for the room.

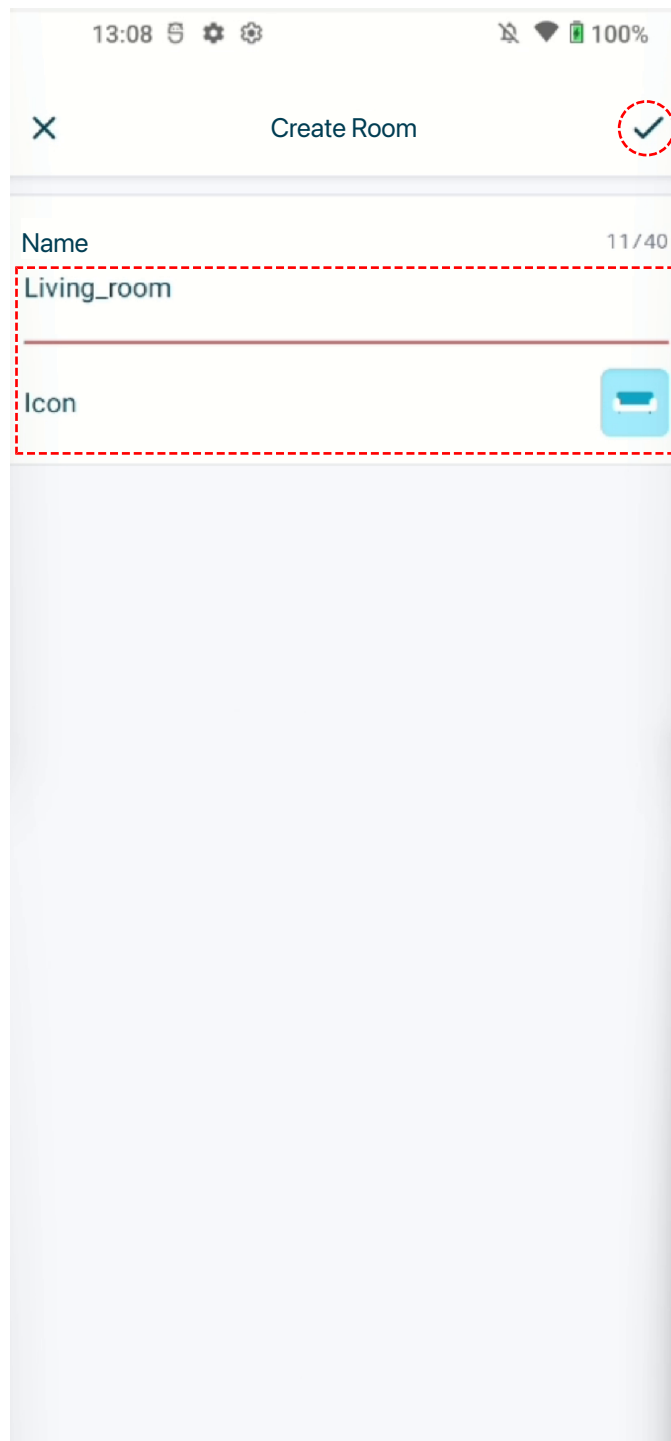

- 4 Tap the checkmark in the top right corner.

Result: The room is now available for assignment.

- 5 Tap the room name to assign the accessory to it. A checkmark appears next to the name of the room to indicate it is currently selected.

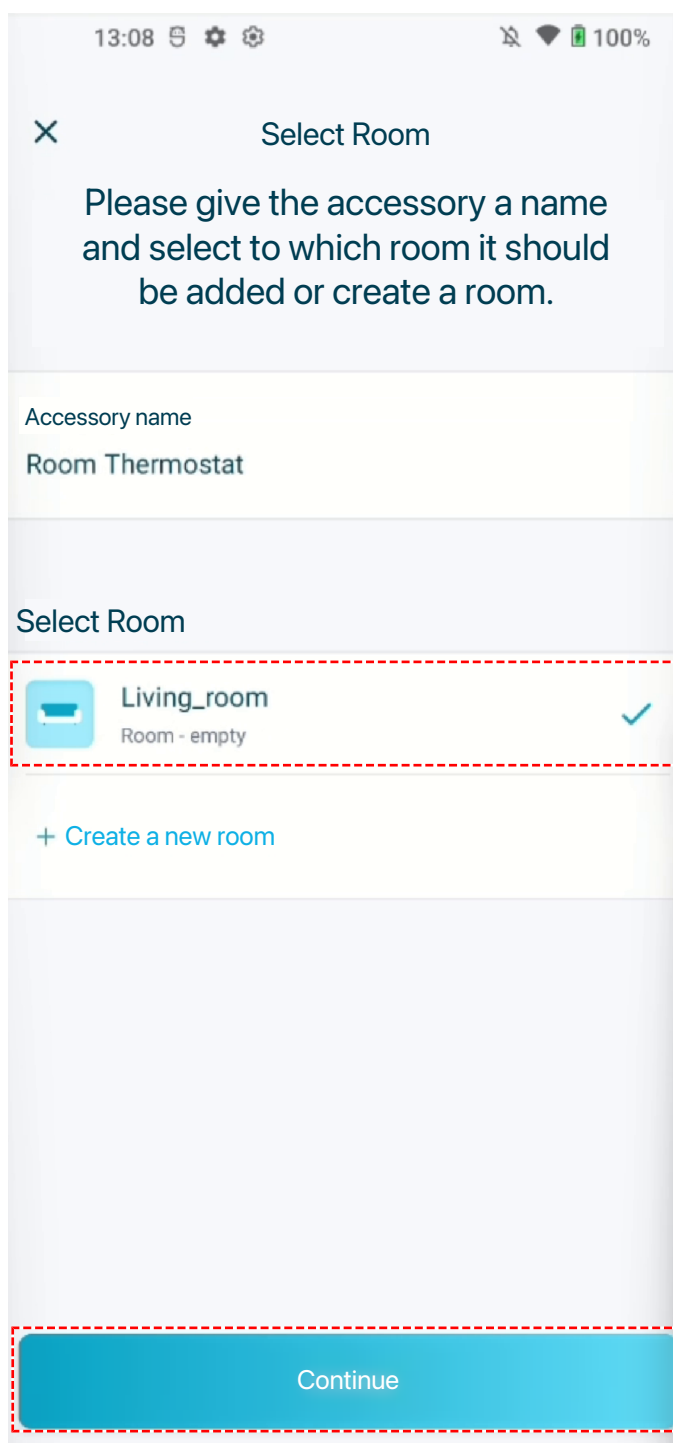

6 Tap Continue.

Result: The accessory is now assigned to the room.

It is possible to assign multiple accessories to a single room. This allows some accessories to leverage information of other accessories. For example, the DHC Radiator Thermostat can use the temperature sensor information provided by a DHC Room Thermostat to regulate its valve. The DHC Radiator Thermostat has its own temperature sensor, but can benefit from a more accurate temperature reading of a DHC Room Thermostat mounted further away from the radiator.

2.4 DHC Floor Heating Controller



INFORMATION

When installing the DHC Floor Heating Controller, spread the underfloor heating loops (even if they are in the same room) over as many heating zones as possible, even if the heating zone has more than 1 connection for heating valves. For more information, see "[10.1.2 About multi-zoning](#)" [▶ 78] and the installation and operation manual of the DHC Floor Heating Controller.

2.4.1 To add a DHC Floor Heating Controller to the ONECTA app

Prerequisite: The DHC Access Point has been set up and added to the ONECTA app. See "[2.1 DHC Access Point setup](#)" [▶ 14] for more information.

- 1 Open the ONECTA app on your mobile device.
- 2 Tap + in the top right corner.

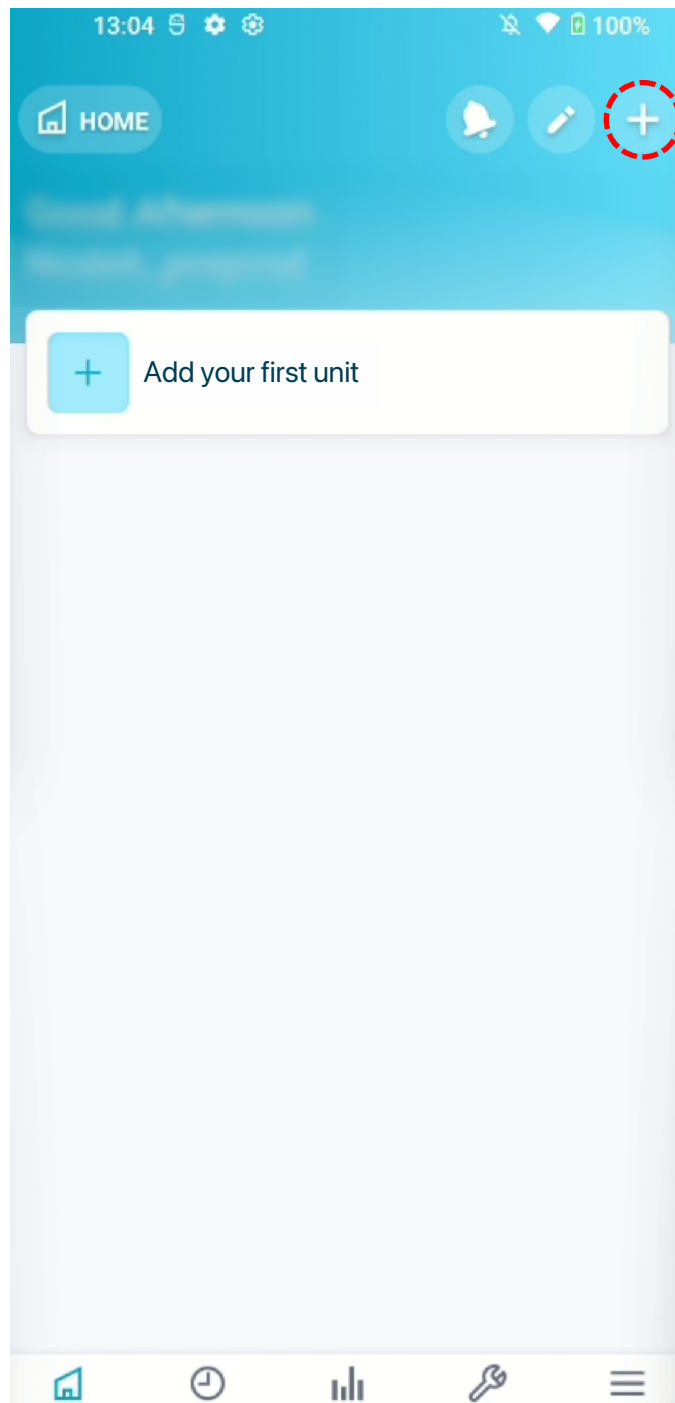

- 3 In the menu, select Add a device.

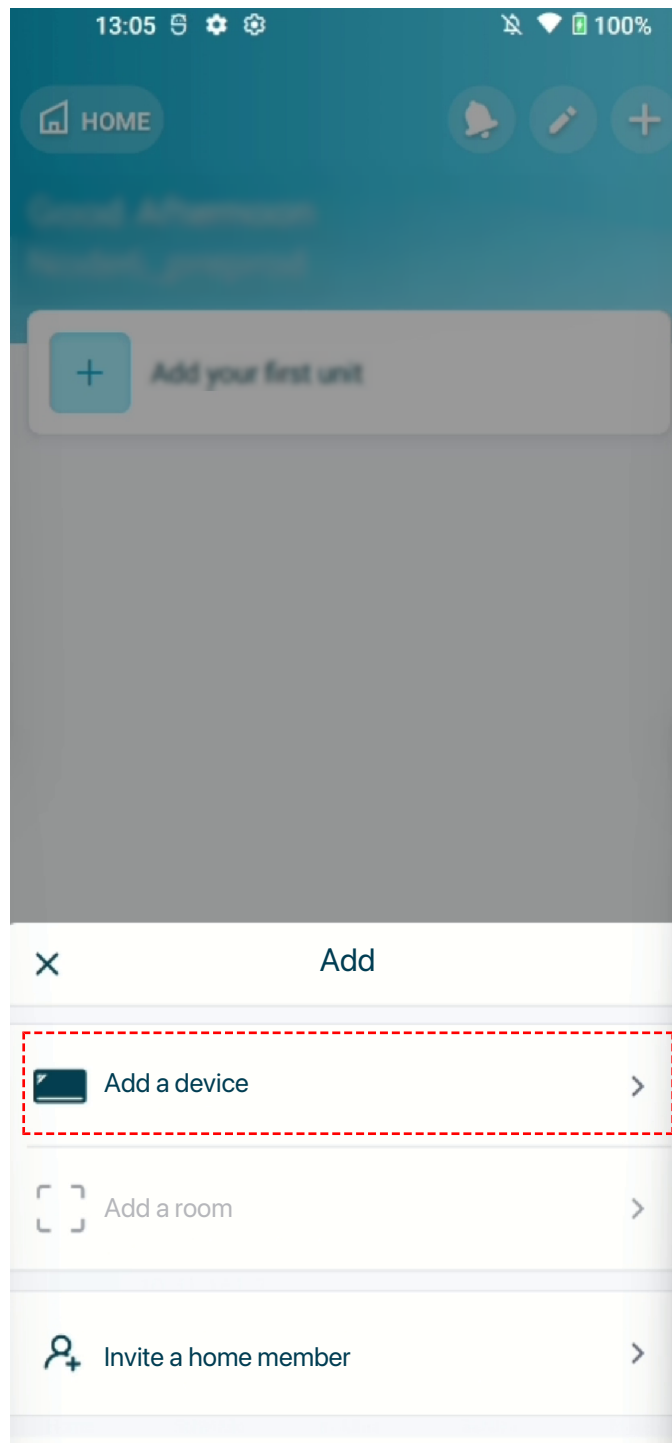

4 Select Daikin Home Controls.

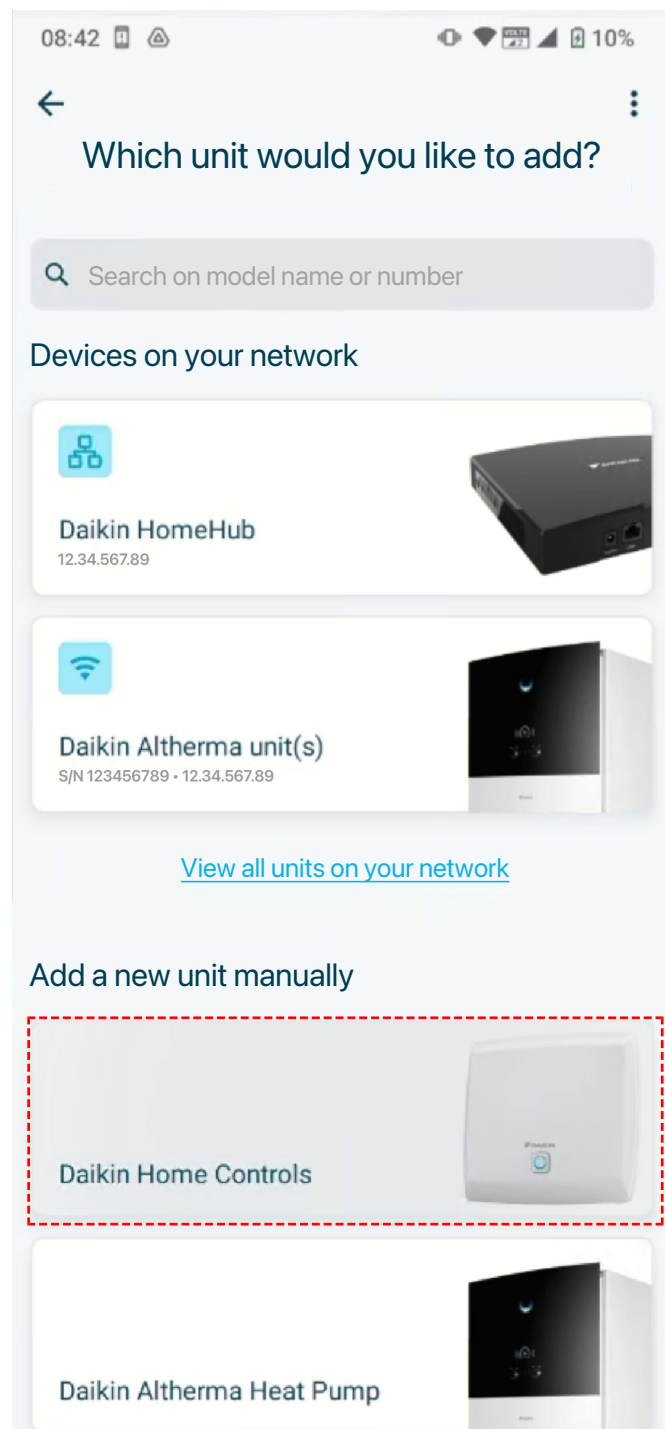

Result: The menu lists the previously connected DHC Access Point, and other connected DHC accessories.

- 5 Briefly press the system button  on the DHC Floor Heating Controller to put the device in connection mode.
- 6 In the ONECTA app, select Add DHC Accessory.

Result: The DHC Access Point starts searching for devices that are ready to pair.

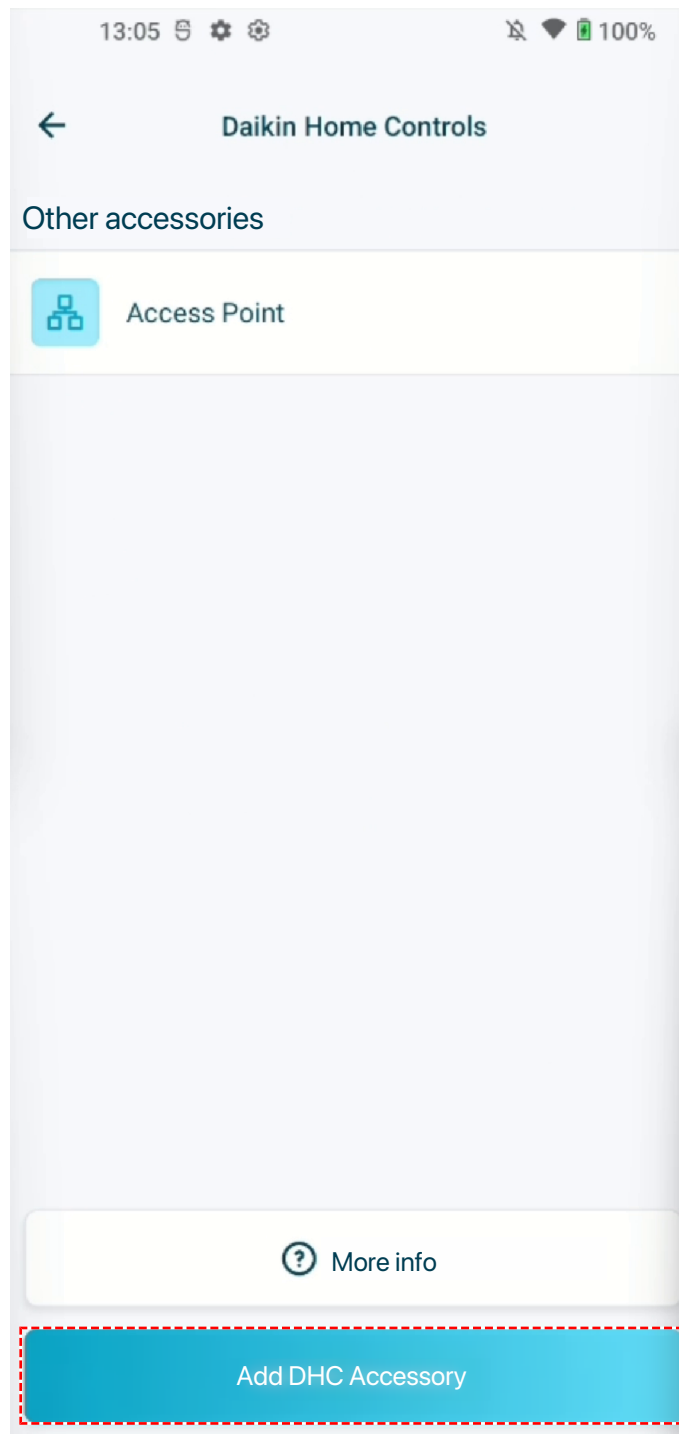

- 7 Enter the SGTIN code of the device. Alternatively, scan the QR code on the Floor Heating Controller.

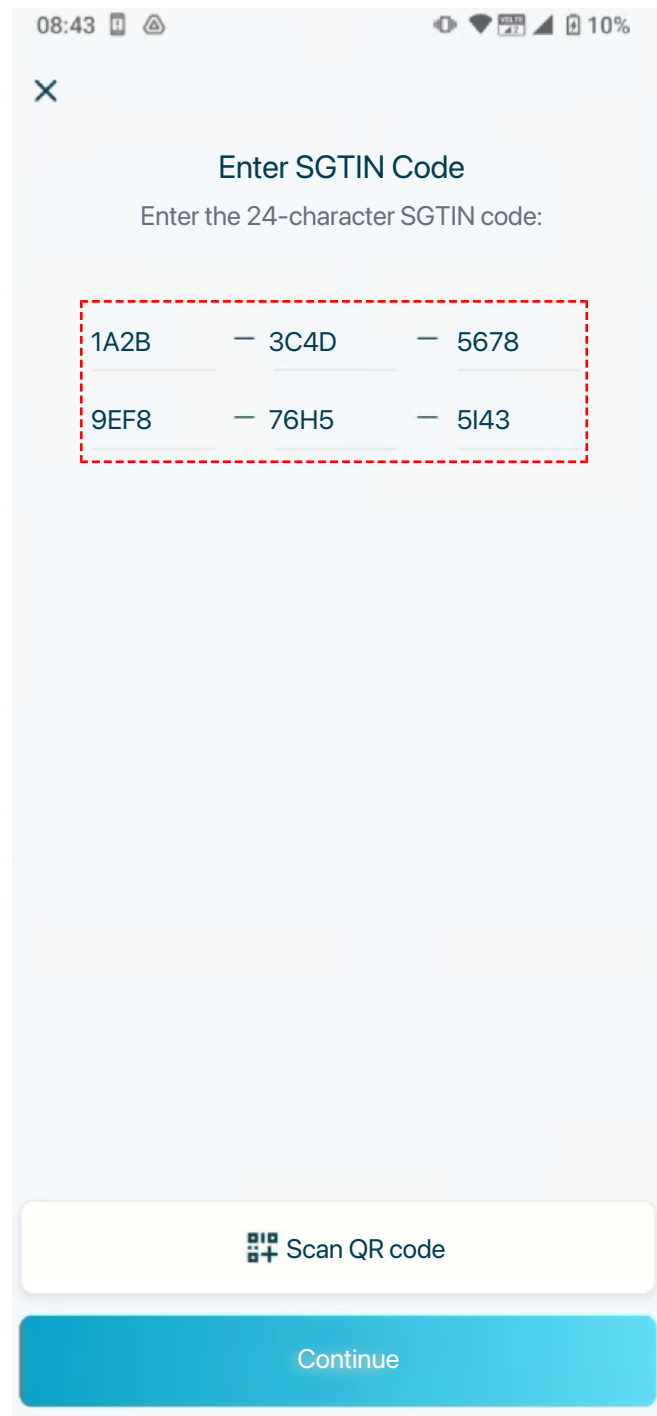

- 8 Wait for the connection to establish.
- 9 Name the device.

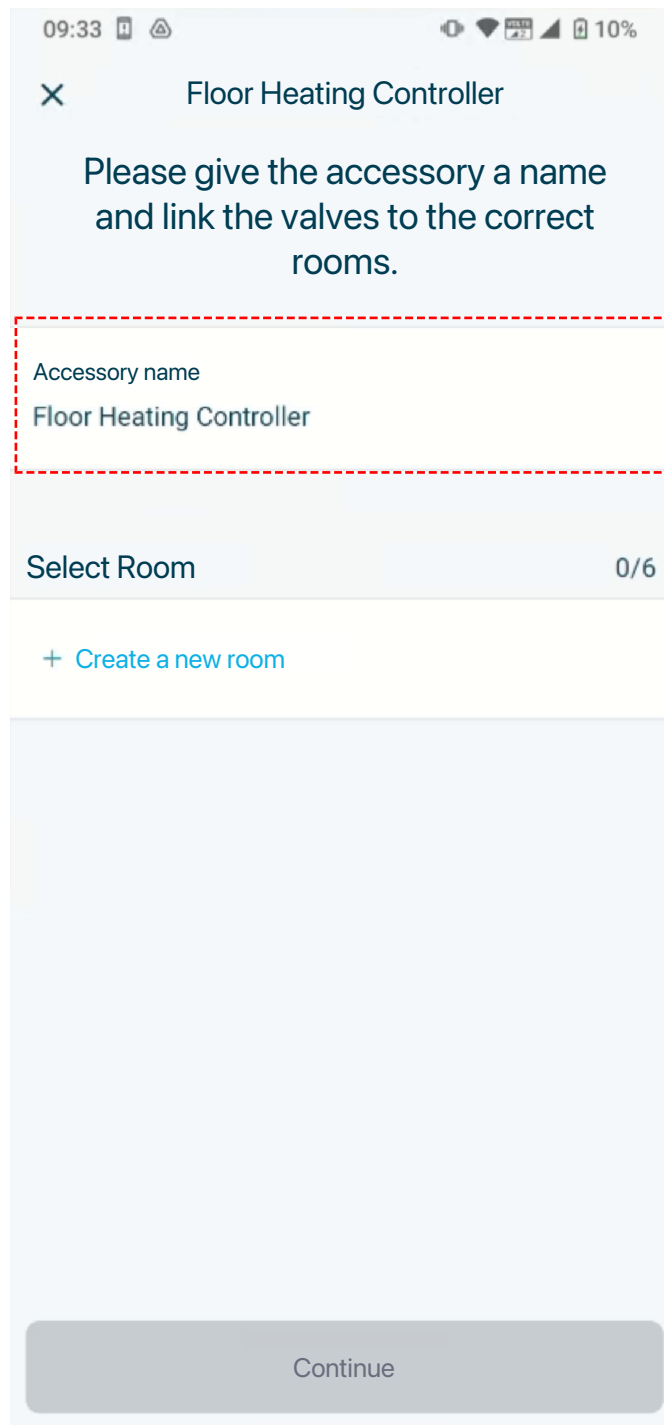

- 10 Tap a room name and set the emitter type for the emitters in that room. Then, assign heating zones to your room. A selected heating zone will have a checkmark next to it to indicate it is currently selected. Do this until all heating zones are assigned to the correct rooms.

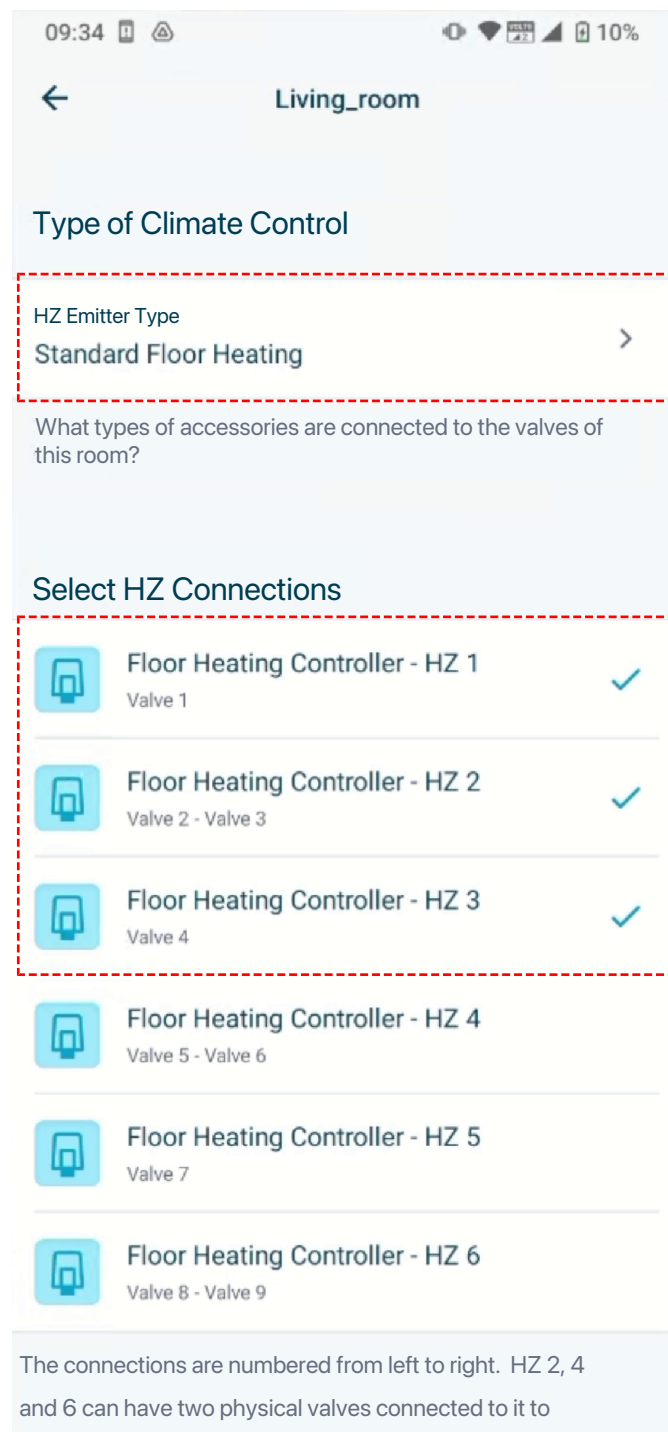
**NOTICE**

For optimal efficiency of the system, it is strongly recommended to follow the principles laid out in the examples in ["10.1.2 About multi-zoning"](#) [78].

11 Tap Continue.

12 Wait for the connection to establish and tap Close.

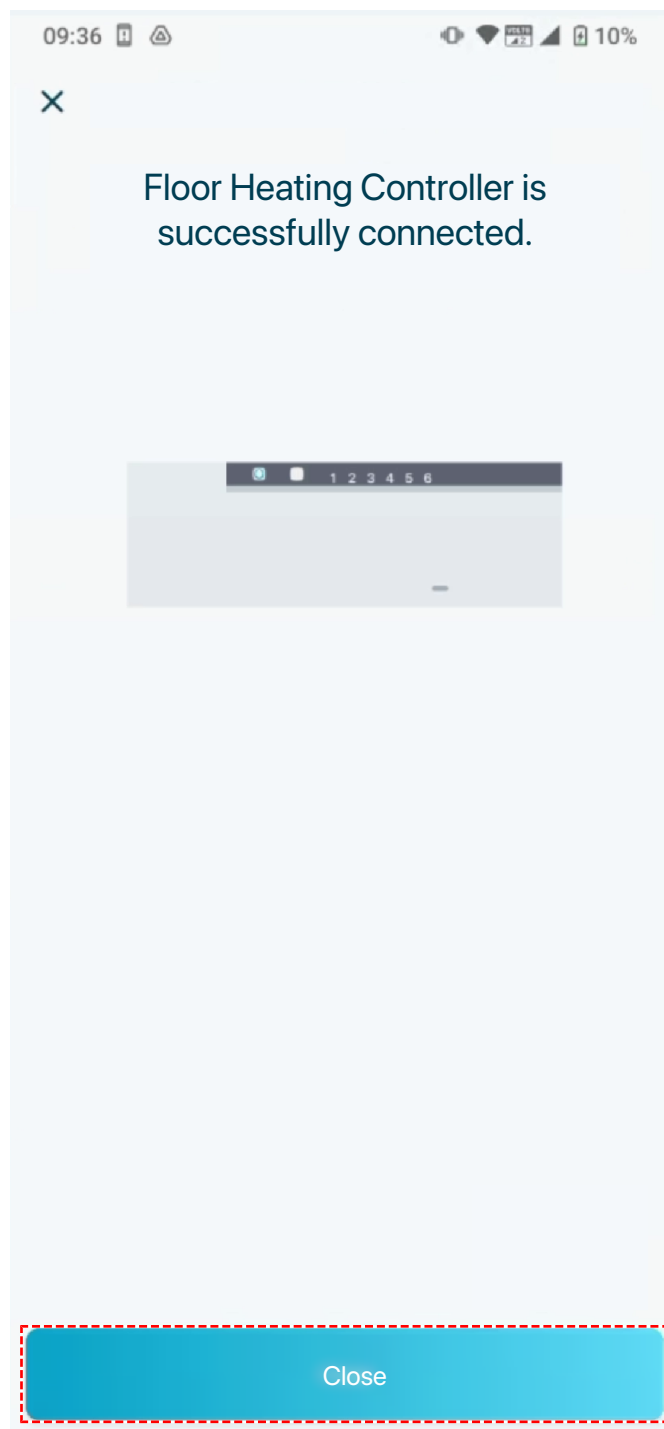

Result: The DHC Floor Heating Controller is added to the ONECTA app.



NOTICE

After adding a DHC Floor Heating Controller it is possible that the ONECTA app warns about an incomplete Daikin Home Controls setup for specific rooms. The room needs a DHC Room Thermostat or a DHC Room Sensor in order to monitor the temperature and/or control the setpoint for that room.

2.5 Setup test



INFORMATION

A successful test of the setup does not guarantee that the system will always work without problems. The DHC accessories require a minimal consistent RF signal strength in order to function as intended. External factors may influence the RF signal strength at any time, even when initial tests did not indicate any issues.

After adding accessories to the ONECTA app, it is recommended to test the setup to verify that all accessories behave as intended, and that the Daikin Altherma unit responds to demand requested by the DHC ecosystem.

- 1 In the ONECTA app, verify that the RF signal strength for every connected accessory is sufficient. The RF signal strength should be better than poor.
- 2 Manually change the setpoint on the DHC Room Thermostats or the DHC Radiator Thermostats. For every manual setpoint change, verify that:
 - The LED of the accessory lights up green. No flashing antenna symbol (📶) is visible on the display of the accessory. For more detailed information about the LED behaviour and status symbols of the accessory, see the installer and user reference guide of the accessory.
 - The setpoint value changes in the ONECTA app.
- 3 Generate heat demand by **changing the setpoints for all rooms to a value that is much higher (in case of heating) than the current room temperature.** Verify that the IO Box is triggering the Daikin Altherma unit. To make sure that the system initially responds to requests for demand, the difference in value between the room temperature and the setpoint must be high enough (at least a 1.5°C difference is recommended), and there must be demand in all rooms.
 - For the DHC Floor Heating Controller, change the setpoint and verify that the valves are adjusted. The IO Box should also request heat demand to the Daikin Altherma unit. Note that after power cycling the DHC Floor Heating Controller, all valves are opened and the Floor Heating Controller requests heat demand on the IO Box for 15 minutes. However, it can take up to 30 minutes before DHC accessories respond to requests for demand. Make sure to wait the full 30 minutes to verify that the accessories respond the demand as expected. After this initial 30 minute duration, the DHC Floor Heating Controller **decides the positions the valves will switch between every 15 minutes.**
- 4 Change the setpoint in the ONECTA Verify that the setpoint on the DHC accessory has changed to whichever setpoint was set on the ONECTA app.

If any accessory is not responding as expected, see "[8 Troubleshooting](#)" [▶ 68] for possible solutions.

3 Applications



INFORMATION

Control actions such as changing the setpoints or schedules can **ONLY** be performed on the DHC Room Thermostat or via the ONECTA app. While the DHC Room Thermostat and the DHC Room Sensor can both function as temperature and humidity sensor (i.e. they can be used interchangeably in many applications), it is **NOT** possible to physically change the setpoint or schedule on the DHC Room Sensor, as it has no screen or buttons to interact with.

3.1 Single zone

3.1.1 Single zone heating only



NOTICE

The MMI settings **MUST** be adjusted first. See "[6 Daikin Altherma user interface settings](#)" [▶ 61].

Radiator

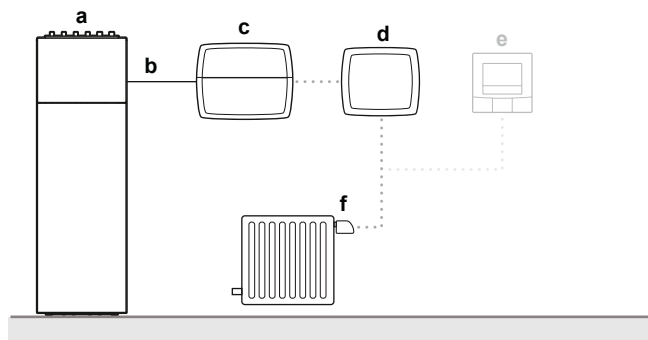

- a** Daikin Altherma
- b** Radiator demand
- c** DHC Basic IO Box
- d** DHC Access Point
- e** (Optional) DHC Room Thermostat — 1 or 2, or DHC Room Sensor
- f** DHC Radiator Thermostat

Underfloor heating

For this application, there **MUST** be one DHC Room Thermostat — 1 or 2, or DHC Room Sensor present per room you wish to control.

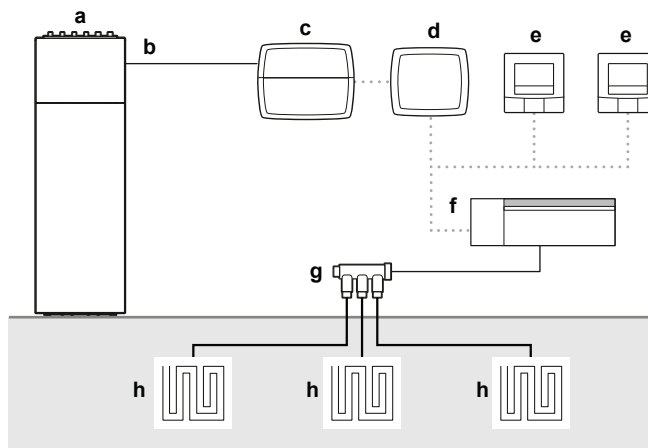

- a Daikin Altherma
- b Radiator demand
- c DHC Basic IO Box
- d DHC Access Point
- e DHC Room Thermostat — 1 or 2, or DHC Room Sensor
- f DHC Floor Heating Controller
- g Collector
- h Underfloor heating

3.1.2 Single zone heating/cooling



NOTICE

The MMI settings **MUST** be adjusted first. See "[6 Daikin Altherma user interface settings](#)" [▶61].

For this application, there **MUST** be one DHC Room Thermostat — 1 or 2, or DHC Room Sensor present per room you wish to control.

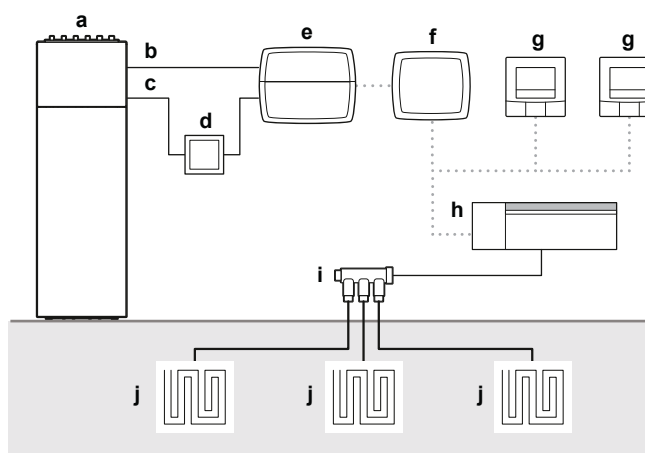

- a Daikin Altherma
- b Underfloor heating demand
- c Heating/cooling
- d Relay
- e DHC Multi IO Box
- f DHC Access Point
- g DHC Room Thermostat — 1 or 2, or DHC Room Sensor
- h DHC Floor Heating Controller
- i Collector
- j Underfloor heating



INFORMATION

If your Daikin Altherma is reversible, it is **ONLY** possible to change the operating mode on the unit or in the ONECTA app. It is **NOT** possible to switch the operation mode directly on the DHC accessories.

3.1.3 Single zone to dual zone



NOTICE

The MMI settings **MUST** be adjusted first. See "[6 Daikin Altherma user interface settings](#)" [▶61].

It is possible to create a dual zone application with a single zone unit. This can be done by using an extra shut-off valve, as shown in the figure.

In this setup, the radiators on the ground floor are monitored by a room thermostat (HCI), the radiators on the first floor are monitored by the DHC accessories (DHC Radiator Thermostat and DHC Room Thermostat).

The shut-off valve is driven by a control signal from the Daikin Altherma that reflects the heat demand signal generated by the HCI. Depending on the configuration, this can be a normally closed or normally open valve.

If the HCI activates a heat demand, the shut-off valve will open and both loops will be supplied with warm water from the unit.

If the HCI does not activate a heat demand, the shut-off valve remains closed. In this case, the heat demand is determined by the DHC accessories and only the water circuit on the first floor receives warm water.

See the installer reference guide of your Daikin Altherma to determine which signal from X2M can be used to control the shut-off valve in a dual zone combination.

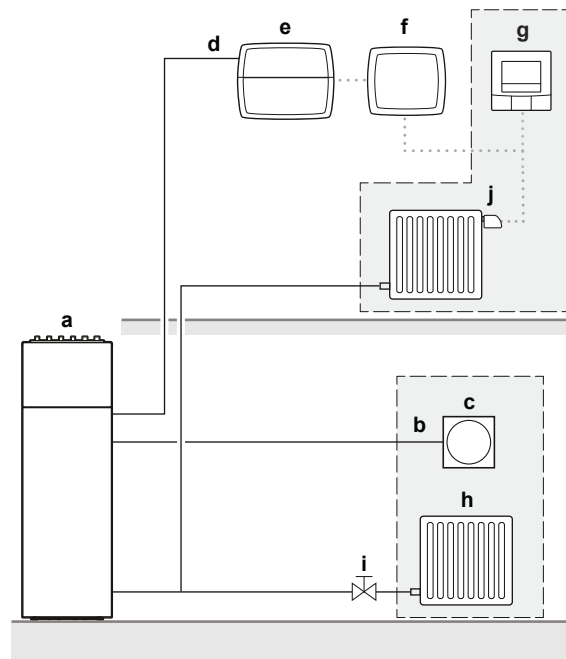

- a** Daikin Altherma
- b** P1/P2
- c** Human Comfort Interface (BRC1HHDA)
- d** External room thermostat demand
- e** DHC Basic IO Box
- f** DHC Access Point
- g** DHC Room Thermostat
- h** Radiator
- i** Shut-off valve
- j** DHC Radiator Thermostat

3.1.4 Special application: Single zone reversible with dehumidifier



INFORMATION

This special application is ONLY available in Italy.



NOTICE

- Your Daikin Altherma unit MUST be added to the ONECTA app via a WLAN module or cartridge. This configuration does NOT work with a LAN adapter.
- The DHC accessories need wireless communication to work. Metal can block the signal. Do NOT put any of the DHC accessories inside a metal box.

**INFORMATION**

The following third-party dehumidifiers are supported:

- IT.RE* (officially supported)
- IT.RS* (officially supported)
- Other third-party dehumidifiers. While these humidifiers are NOT officially supported, they can still be connected in most cases. For more information, see the installation manual of the floor cooling connection kit (EKRK).

**NOTICE**

The MMI settings **MUST** be adjusted first. See "[6 Daikin Altherma user interface settings](#)" [▶ 61].

With a reversible Daikin Altherma unit, floor cooling can be provided. Cooling can cause condensation if the humidity level is too high. The DHC accessories provide a means to measure the relative humidity and temperature of the room and, in combination with the floor cooling connection kit (EKRK), provide a solution that will take countermeasures to prevent wet floors based upon the detected relative humidity level. The following accessories can measure relative humidity and temperature:

- **DHC Room Thermostat — 1 or 2**
- **DHC Room Sensor**

When the dehumidifier is connected to the underfloor heating of a Daikin Altherma system, the dehumidifier needs to know when cold water is prepared by the Daikin Altherma indoor unit in order to function correctly. In this application, the floor cooling connection kit (EKRK) serves as an interface to transfer signals between the DHC Multi IO Box, the Daikin Altherma unit and the air dehumidifier. When floor cooling is active and the Daikin Altherma unit is NOT preparing domestic hot water, the floor cooling connection kit (EKRK) signals this to the dehumidifier. With this information, the dehumidifier can start working when it is required.

The application will:

- Activate the dehumidifier when **Humidity limit 1**⁽¹⁾ is reached on any of the humidity sensors, and
- Stop the cooling process by closing the valves of the floor cooling when **Humidity limit 2**⁽¹⁾ is reached. The dehumidifier is still activated.
 - When using a IT.RE* type third-party dehumidifier, it is possible to configure the humidity limit on the dehumidifier itself instead of setting **Humidity limit 2** on the Daikin Altherma user interface.
 - It is also possible to connect a third-party humidity sensor. However, the sensor must be configured to trigger the closing of the valves by connecting to the floor cooling connection kit (EKRK) whenever a certain limit is reached. In this case, the **Humidity limit 2** setting on the Daikin Altherma user interface is also NOT used.

For more information about triggering humidity limits, see the installation manual of the floor cooling connection kit (EKRK). For more information about connecting the dehumidifier or any third-party sensors to the floor cooling connection kit (EKRK), see the wiring diagram in "[9.2 DHC Multi IO Box](#)" [▶ 73].s

⁽¹⁾ For more information see "[6.3 Settings for special applications](#)" [▶ 65].

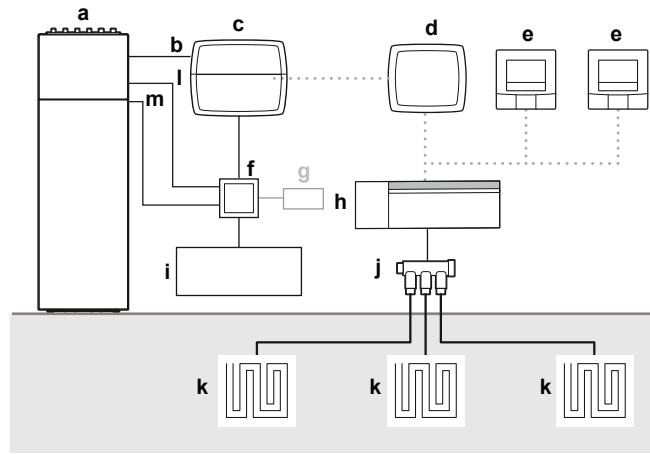

- a Daikin Altherma
- b Underfloor heating demand
- c DHC Multi IO Box
- d DHC Access Point
- e DHC Room Thermostat — 1 or 2, or DHC Room Sensor
- f Floor cooling connection kit (EKRK)
- g (Optional) Dew sensor
- h DHC Floor Heating Controller
- i Dehumidifier
- j Collector
- k Underfloor heating
- l Heating/cooling
- m Domestic hot water ON



INFORMATION

If your Daikin Altherma is reversible, it is ONLY possible to change the operating mode on the unit or in the ONECTA app. It is NOT possible to switch the operation mode directly on the DHC accessories.

Configuration

The configuration is done by adding the Daikin Altherma unit in the ONECTA app. For more information on how to do so, see the manuals of the DHC Access Point. Alternatively, you can follow the in-app instructions provided in the ONECTA app.

After setting the presence of the dehumidifier and adjusting the installer mode settings on the Daikin Altherma unit, the ONECTA app will automatically take care of all configurations of the DHC accessories.

Configuration of the dehumidifier

These settings ONLY apply to a dehumidifier of type RE*. No configuration is required for a dehumidifier of type RS*. For more detailed information on configuration, see the manual of the respective dehumidifier.

			Description	Value
17-IC	Treatment input	Invert logic	Used to switch on/off heating/cooling/dehumidification functions.	No
18-IC	Season input		Used to set the season (summer/winter).	No
11-14	Dew point alarm		Triggered when dew point alarm is reached.	No

3.1.5 Special application: Single zone reversible without dehumidifier

**NOTICE**

- Your Daikin Altherma unit **MUST** be added to the ONECTA app via a WLAN module or cartridge. This configuration does **NOT** work with a LAN adapter.
- The DHC accessories need wireless communication to work. Metal can block the signal. Do **NOT** put any of the DHC accessories inside a metal box.

**NOTICE**

The MMI settings **MUST** be adjusted first. See "[6 Daikin Altherma user interface settings](#)" [▶ 61].

The special application described in "[3.1.4 Special application: Single zone reversible with dehumidifier](#)" [▶ 50] can also be used without a dehumidifier. However, without a dehumidifier to help prevent possible condensation during cooling in case of high humidity, the only countermeasure is to stop cooling operation entirely. This application does **NOT** require the installation of a dehumidifier or the floor cooling connection kit (EKRK). The Daikin Altherma unit is connected to the DHC Multi IO Box directly.

The application will:

- Stop the cooling process by closing the valves of the floor cooling when **Humidity limit 2⁽¹⁾** is reached.

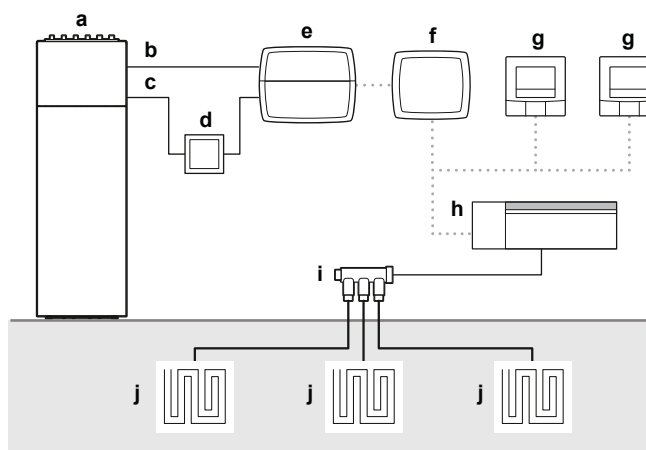

- a Daikin Altherma
- b Underfloor heating demand
- c Heating/cooling
- d Relay
- e DHC Multi IO Box
- f DHC Access Point
- g DHC Room Thermostat — 1 or 2, or DHC Room Sensor
- h DHC Floor Heating Controller
- i Collector
- j Underfloor heating

**INFORMATION**

If your Daikin Altherma is reversible, it is **ONLY** possible to change the operating mode on the unit or in the ONECTA app. It is **NOT** possible to switch the operation mode directly on the DHC accessories.

⁽¹⁾ For more information see "[6.3 Settings for special applications](#)" [▶ 65].

3.2 Bizone

3.2.1 Bizone heating only



NOTICE

The MMI settings MUST be adjusted first. See "[6 Daikin Altherma user interface settings](#)" [▶ 61].

For this application, there MUST be one DHC Room Thermostat — 1 or 2 present per room you wish to control. Alternatively, a DHC Room Sensor can also be used instead. If there's a DHC Radiator Thermostat in the room, the DHC Room Thermostat or DHC Room Sensor (whichever is used) is optional.

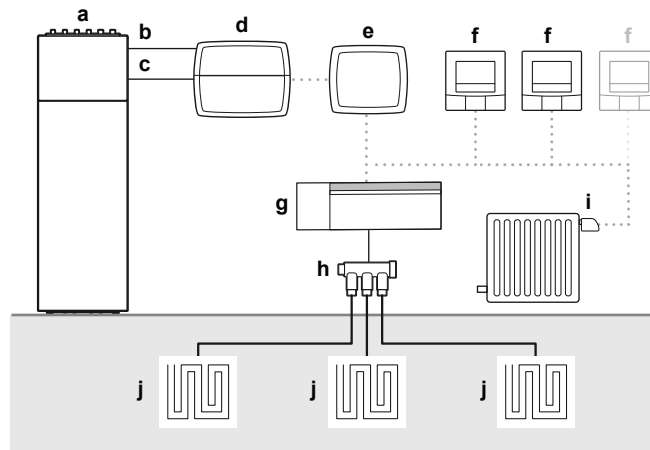

- a Daikin Altherma
- b Underfloor heating demand
- c Radiator demand
- d DHC Basic IO Box
- e DHC Access Point
- f DHC Room Thermostat — 1 or 2, or DHC Room Sensor
- g DHC Floor Heating Controller
- h Collector
- i DHC Radiator Thermostat
- j Underfloor heating

3.2.2 Bizone heating/cooling



NOTICE

The MMI settings MUST be adjusted first. See "[6 Daikin Altherma user interface settings](#)" [▶ 61].

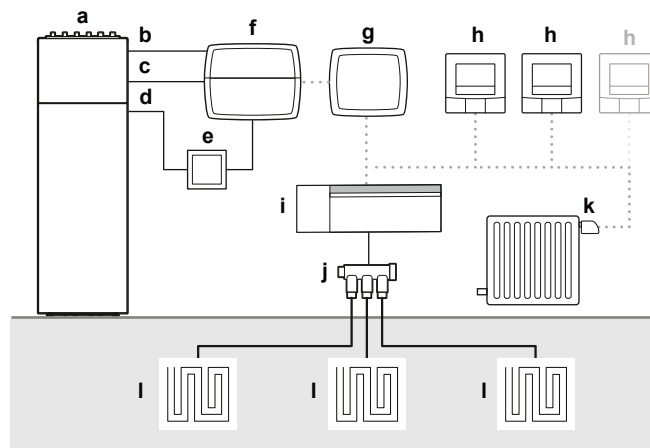

- a** Daikin Altherma
- b** Underfloor heating demand
- c** Radiator demand
- d** Heating/cooling
- e** Relay
- f** DHC Multi IO Box
- g** DHC Access Point
- h** DHC Room Thermostat — 1 or 2, or DHC Room Sensor
- i** DHC Floor Heating Controller
- j** Collector
- k** DHC Radiator Thermostat
- l** Underfloor heating



INFORMATION

If your Daikin Altherma is reversible, it is **ONLY** possible to change the operating mode on the unit or in the ONECTA app. It is **NOT** possible to switch the operation mode directly on the DHC accessories.

3.2.3 Bizone heating only with room thermostat (Human Comfort Interface)



NOTICE

The MMI settings **MUST** be adjusted first. See "[6 Daikin Altherma user interface settings](#)" [▶ 61].

In this application, the Human Comfort Interface (BRC1HHDA) is used to control the main zone with underfloor heating.

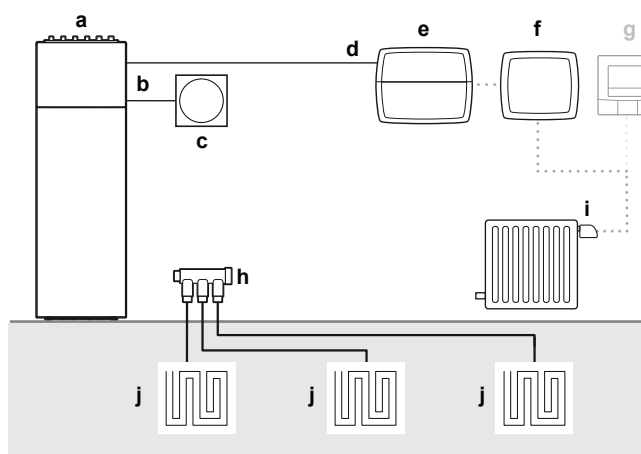

- a** Daikin Altherma
- b** P1/P2
- c** Human Comfort Interface (BRC1HHDA)
- d** Radiator demand
- e** DHC Basic IO Box
- f** DHC Access Point
- g** (Optional) DHC Room Thermostat — 1 or 2, or DHC Room Sensor
- h** Collector
- i** DHC Radiator Thermostat
- j** Underfloor heating

3.2.4 Bizone reversible with room thermostat (Human Comfort Interface)



NOTICE

The MMI settings **MUST** be adjusted first. See "[6 Daikin Altherma user interface settings](#)" [▶ 61].

In this application, the Human Comfort Interface (BRC1HHDA) is used to control the main zone with underfloor heating.

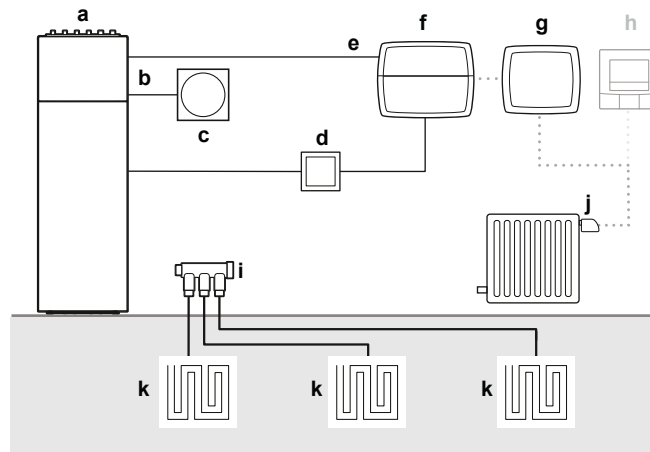

- a Daikin Altherma
- b P1/P2
- c Human Comfort Interface (BRC1HHDA)
- d Relay
- e Radiator demand
- f DHC Multi IO Box
- g DHC Access Point
- h (Optional) DHC Room Thermostat — 1 or 2, or DHC Room Sensor
- i Collector
- j DHC Radiator Thermostat
- k Underfloor heating



INFORMATION

If your Daikin Altherma is reversible, it is **ONLY** possible to change the operating mode on the unit or in the ONECTA app. It is **NOT** possible to switch the operation mode directly on the DHC accessories.

3.2.5 Special application: Bizon heating/cooling with dehumidifier



INFORMATION

This special application is **ONLY** available in Italy.



NOTICE

- Your Daikin Altherma unit **MUST** be added to the ONECTA app via a WLAN module or cartridge. This configuration does **NOT** work with a LAN adapter.
- The DHC accessories need wireless communication to work. Metal can block the signal. Do **NOT** put any of the DHC accessories inside a metal box.



INFORMATION

The following third-party dehumidifiers are supported:

- IT.RE* (officially supported)
- IT.RS* (officially supported)
- Other third-party dehumidifiers. While these humidifiers are **NOT** officially supported, they can still be connected in most cases. For more information, see the installation manual of the floor cooling connection kit (EKRK).



NOTICE

The MMI settings **MUST** be adjusted first. See "[6 Daikin Altherma user interface settings](#)" [▶ 61].

The special application described in "3.1.4 Special application: Single zone reversible with dehumidifier" [▶ 50] can also be used with a bizon configuration⁽¹⁾. However, due to the limited number connections available on the DHC Multi IO Box, the additional zone cannot be driven by the DHC Multi IO Box. To manage demand for the additional zone, install an additional external thermostat. In this application, the demand for the additional zone cannot be managed by the DHC ecosystem.

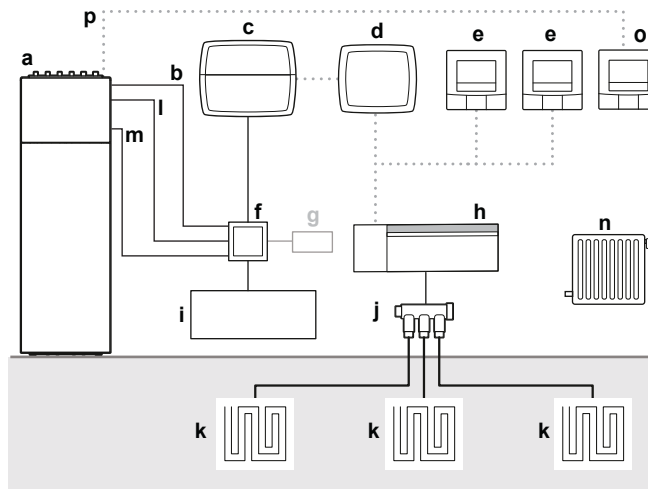

- a Daikin Altherma
- b Underfloor heating demand
- c DHC Multi IO Box
- d DHC Access Point
- e DHC Room Thermostat — 1 or 2, or DHC Room Sensor
- f Floor cooling connection kit (EKRK)
- g (Optional) Dew sensor
- h DHC Floor Heating Controller
- i Dehumidifier
- j Collector
- k Underfloor heating
- l Heating/cooling
- m Domestic hot water ON
- n Radiator (not DHC)
- o External thermostat (not DHC)
- p Radiator demand



INFORMATION

If your Daikin Altherma is reversible, it is ONLY possible to change the operating mode on the unit or in the ONECTA app. It is NOT possible to switch the operation mode directly on the DHC accessories.

⁽¹⁾ The same settings as for the single zone special application apply. For more information see "6.3 Settings for special applications" [▶ 65].

4 Connections to the Daikin Altherma unit

Depending on the type of Daikin Altherma unit, a different DHC accessory is required to connect the unit to the DHC ecosystem.

Unit	Single zone	Bizone
Heating only model	DHC Basic IO Box	
Reversible model	DHC Multi IO Box	

For more information about connecting the of Daikin Altherma unit to DHC, see "[9 Wiring diagram](#)" [▶ 72].

5 Compatibility

Daikin Altherma 3

	Unit	Outdoor	Indoor			DHC compatible
ASHP	Daikin Altherma 3 H HT	EPRA-D2/W1(7)	F	ETVH/X/Z-E(7)	MMI2	Yes
			ECH ₂ O	ETSH(B)/X(B)-P-E(7)		
			W	ETBH/X-D(7)		
	Daikin Altherma 3 H MT	EPRA-E	F	ETVH/X/Z-E		
			ECH ₂ O	ETSH(B)/X(B)-P-E		
			W	ETBH/X-D		
	Daikin Altherma 3 R	ERGA-EV(7)	F	EHVH/X/Z-E		
			ECH ₂ O	EHS(B)/X(B)-P-E		
			W	EHBH/X-E		
	Daikin Altherma 3 R	ERGA-D	F	EHVH/X/Z-D		
			W	EHBH/X-D		
	Daikin Altherma 3 M	EBLA-D EDLA-D	—			
	Daikin Altherma 3 R	ERLA-D	F	EBVH/X/Z-D		
			ECH ₂ O	EBSH/X-D		
W			EBBH/X-D			
Daikin Altherma 3 R	ERLA-D	F	EHFH/Z-S18D3V	EKRUDAL1		
Daikin Altherma 3 H	EPGA-DV	F	EAVH/X/Z-D	MMI		
		W	EABH/X-D			
Daikin Altherma 3 M	EBLA-E EDLA-E	—		MMI2		
Daikin Altherma M	EB/DLQ-CV3 EB/DLQ-CW1 EB/DLQ-C3V3/W1	—		EKRUCBL*		
Daikin Altherma R HT	ERR/SQ-AV1/Y1	EKHBRD-DV/Y17		—	No	
Daikin Altherma R Flex Type	SERHQ-BAW1	SEHVX-BAW		—		
GEO/WS	Daikin Altherma 3 GEO	—	EGSAH/X-D		MMI	Yes
	Daikin Altherma GEO		EGSQH-S18A9W		EKRUCBL*	No
	Daikin Altherma 3 WS		EWSAH/X-D9W		MMI	Yes
Hybrid	Daikin Altherma R Hybrid	EVLQ-CV3	EHYHBH-AV32 + EHYKOMB-A		EKRUCBL*	
	Daikin Altherma H Hybrid	EJHA-AV3	EHY2KOMB28/32A A		EKRUHML*	
Gas	Daikin Altherma 3 C Gas W	—	D2CND-A		—	No
			D2TND-A4			

Daikin Altherma 4

	Unit	Outdoor	Indoor			DHC compatible
ASHP	Daikin Altherma 4 H	EPSK06~14A	F	EPVX10+14S(U)18+23A	MMI4	Yes
			ECH ₂ O	EPSX(B)10+14P30+50A		
			W	EPBX10~14A		

6 Daikin Altherma user interface settings

Daikin Altherma user interface (MMI) upgrade



NOTICE

Upgrade the firmware of the Daikin Altherma user interface to the most recent version.

Room-by-room control



NOTICE

To achieve user-friendly and efficient demand-based, room-by-room control, the DHC configuration requires the Daikin Altherma unit temperature control for the desired zone to be set to **External room thermostat**. This allows the DHC ecosystem to request space/heating cooling demand when a room requires it. It is then possible to regulate the temperature for each room, using the ONECTA app to configure individual room setpoints or schedules.

It is technically possible to achieve some form of room-by-room control by setting the Daikin Altherma unit temperature control for the desired zone to **Leaving water**, in combination with separate room thermostats to regulate the flow in each room. However, this solution could lead to situations where there is space heating/cooling generation by the Daikin Altherma unit when there is no room that has any request for it. Contrarily, it is possible that no space cooling/heating is generated by the the Daikin Altherma unit while there are rooms with a request for it. Note that traditional room-based thermostats can also not be integrated in the ONECTA app.

6.1 Settings for single zone

Daikin Altherma 3

Menu item	Mode	Description	Value
Main zone > Control	Installer mode ONLY	This setting defines that the main zone will be activated to produce water for space heating/cooling based on the input of the ext. RT contact(s).	External room thermostat
Main zone > Ext thermostat type		This setting configures the external room thermostat contact for the main zone (low temperature emitters) as a single thermo request.	1 contact

Daikin Altherma 4

Menu item	Mode	Description	Value
[1.12] Main zone > Control	Installer mode ONLY	This setting defines that the main zone will be activated to produce water for space heating/cooling based on the input of the ext. RT contact(s).	External room thermostat
[1.13] Main zone > External room thermostat > Input source		This setting defines the input source of the external room thermostat for the main zone.	Hardware
[1.13] Main zone > External room thermostat > Connection type		This setting configures the external room thermostat contact for the main zone (low temperature emitters) as a single thermo request.	Single contact

6.2 Settings for bizona

Bizona without room thermostat — Daikin Altherma 3

Menu item	Mode	Description	Value
Main zone > Control	Installer mode ONLY	This setting defines that the main zone will be activated to produce water for space heating/cooling based on the input of the ext. RT contact(s).	External room thermostat
Main zone > Ext thermostat type		This setting configures the external room thermostat contact for the main zone (low temperature emitters) as a single thermo request.	1 contact
Additional zone > Control		This setting defines that the additional zone will be activated to produce water for space heating/cooling based on the input of the ext. RT contact(s).	External room thermostat
Additional zone > Ext thermostat type		This setting configures the external room thermostat contact for the additional zone (high temperature emitters) as a single thermo request.	1 contact

Bizone with room thermostat — Daikin Altherma 3

Menu item	Mode	Description	Value
Main zone > Control	Installer mode ONLY	This setting defines that the room temperature is controlled by the dedicated Human Comfort Interface (BRC1HHDA used as room thermostat)	Room thermostat
Additional zone > Control		This setting defines that the additional zone will be activated to produce water for space heating/cooling based on the input of the ext. RT contact(s).	External room thermostat
Additional zone > Ext thermostat type		This setting configures the external room thermostat contact for the additional zone (high temperature emitters) as a single thermo request.	1 contact

Bizone without room thermostat — Daikin Altherma 4

Menu item	Mode	Description	Value
[1.12] Main zone > Control	Installer mode ONLY	This setting defines that the main zone will be activated to produce water for space heating/cooling based on the input of the ext. RT contact(s).	External room thermostat
[1.13] Main zone > External room thermostat > Input source		This setting defines the input source of the external room thermostat for the main zone.	Hardware
[1.13] Main zone > External room thermostat > Connection type		This setting configures the external room thermostat contact for the main zone (low temperature emitters) as a single thermo request.	Single contact
[2.12] Additional zone > Control		This setting defines that the additional zone will be activated to produce water for space heating/cooling based on the input of the ext. RT contact(s).	External room thermostat
[2.13] Additional zone > External room thermostat > Input source		This setting defines the input source of the external room thermostat for the additional zone.	Hardware
[2.13] Additional zone > External room thermostat > Connection type		This setting configures the external room thermostat contact for the additional zone (high temperature emitters) as a single thermo request.	Single contact

Bizone with room thermostat — Daikin Altherma 4

Menu item	Mode	Description	Value
[1.12] Main zone > Control	Installer mode ONLY	This setting defines that the room temperature is controlled by the dedicated Human Comfort Interface (BRC1HHDA used as room thermostat)	Room thermostat
[2.12] Additional zone > Control		This setting defines that the additional zone will be activated to produce water for space heating/cooling based on the input of the ext. RT contact(s).	External room thermostat
[2.13] Additional zone > External room thermostat > Input source		This setting defines the input source of the external room thermostat for the additional zone.	Hardware
[2.13] Additional zone > External room thermostat > Connection type		This setting configures the external room thermostat contact for the additional zone (high temperature emitters) as a single thermo request.	Single contact

6.3 Settings for special applications

Daikin Altherma 3

Menu item	Mode	Description	Value
Daikin Home Controls > Enable Daikin Home Controls	Installer mode ONLY	This setting defines the visibility of settings related to special applications. ^(a)	Yes
Menu item (Daikin Home Controls > Dehumidifier > ...)	Mode	Description	Value
Dehumidifier installed	Installer mode ONLY	This setting defines the presence of a dehumidifier in the system. ^(b)	Yes
Dew sensor installed		This setting defines the presence and type of external dew sensor connected to the Floor cooling connection kit (EKRRK). Only relevant for Humidity limit 2.	<ul style="list-style-type: none"> ▪ No (in case of RS*) ▪ Normally open ▪ Normally closed (in case of RE*)
Humidity limit 1	User mode	When this level of relative humidity is reached, the dehumidifier is activated.	<ul style="list-style-type: none"> ▪ Range: 40-80% ▪ Default: 55%

Menu item	Mode	Description	Value
Humidity limit 2	Installer mode ONLY	When this level of relative humidity is reached, the floor cooling is stopped. ^(c)	<ul style="list-style-type: none"> ▪ Range: 41-80% ▪ Default: 70%

^(a) This setting ONLY defines the visibility of other settings related to special applications. Disabling this setting does NOT disable Daikin Home Controls.

^(b) In case of the special application without dehumidifier, this setting ONLY defines whether or not the special application is being used. While this specific special application does NOT make use of a dehumidifier, this setting MUST still be set to **Yes**.

^(c) This humidity limit can be configured on the dehumidifier (in case of a third-party IT.RE* type dehumidifier). When using a third-party humidity sensor, the limit must be configured for the sensor to trigger at the appropriate time. In both of these cases, this setting can be ignored. The sensor type can still be set using the **Dew sensor installed** menu item.

Daikin Altherma 4

Menu item	Mode	Description	Value
[8.5.1] Connectivity > Daikin Home Controls > Enable Daikin Home Controls	User mode	This setting defines the visibility of settings related to special applications. ^(a)	Yes
[8.5.2] Dehumidifier installed		This setting defines the presence of a dehumidifier in the system. ^(b)	Yes
[8.5.3] Dew sensor installed		This setting defines the presence and type of external dew sensor connected to the Floor cooling connection kit (EKRRK). Only relevant for Humidity limit 2 .	<ul style="list-style-type: none"> ▪ No (in case of RS*) ▪ Normally open ▪ Normally closed (in case of RE*)
[8.5.4] Humidity limit 1		When this level of relative humidity is reached, the dehumidifier is activated.	<ul style="list-style-type: none"> ▪ Range: 40-80% ▪ Default: 55%
[8.5.5] Humidity limit 2		When this level of relative humidity is reached, the floor cooling is stopped. ^(c)	<ul style="list-style-type: none"> ▪ Range: 41-80% ▪ Default: 70%

^(a) This setting ONLY defines the visibility of other settings related to special applications. Disabling this setting does NOT disable Daikin Home Controls.

^(b) In case of the special application without dehumidifier, this setting ONLY defines whether or not the special application is being used. While this specific special application does NOT make use of a dehumidifier, this setting MUST still be set to **Yes**.

^(c) This humidity limit can be configured on the dehumidifier (in case of a third-party IT.RE* type dehumidifier). When using a third-party humidity sensor, the limit must be configured for the sensor to trigger at the appropriate time. In both of these cases, this setting can be ignored. The sensor type can still be set using the **Dew sensor installed** menu item.

7 Firmware updates

In order to keep your DHC accessories and supported devices always up to date and to be able to make use of the full range of functions, the ONECTA cloud will automatically update the device software (firmware) of the components.

As a rule, the firmware of the DHC accessories is updated in the background via radio connection. Your DHC accessories will remain active during the update.

8 Troubleshooting

8.1 Resetting to factory settings

The factory settings of your DHC accessories as well as of your entire installation can be restored.

- **Resetting a DHC accessory:** Only the factory settings of the DHC accessory will be restored. The entire installation will NOT be deleted.
- **Resetting and deleting the entire installation:** The entire installation is removed. The factory settings of your individual DHC accessories have to be restored so they can be connected again.

8.1.1 To reset and delete the entire installation



INFORMATION

During the reset, the DHC Access Point MUST be connected to the cloud so that all data can be deleted. This means that the network cable MUST be plugged in during the process and the LED MUST light up blue continuously.

To reset the factory settings of the entire installation, the DHC Access Point MUST be reset twice in succession, within 5 minutes:

- 1 Reset the DHC Access Point. See "[8.1.2 To reset the DHC Access Point](#)" [▶ 68].
- 2 Wait at least 10 seconds until the LED permanently lights up blue.
- 3 Immediately afterwards, perform the reset for the second time.

Result: After the second restart, your system has been reset.

DHC Access Point still visible

If the DHC Access Point is still visible in the app (status offline) after resetting, you have to manually remove it:

- 1 Click on the plus symbol (+).
- 2 Select the menu item **Add Daikin Home Controls**.
- 3 Check if your DHC Access Point is in the list.
- 4 Select **Remove**.

Result: Your DHC Access Point has been removed from the app.

8.1.2 To reset the DHC Access Point

- 1 Disconnect the DHC Access Point from the power supply by unplugging the mains adapter.
- 2 Press the system button and plug in the mains adapter again at the same time, until the LED starts flashing orange.
- 3 Release the system button.
- 4 Press the system button again, until the LED lights up green. If the LED lights up red, try again.
- 5 Release the system button to finish the procedure.

8.1.3 To reset the DHC Radiator Thermostat

- 1 Open the battery compartment by pulling it down.
- 2 Remove a battery.
- 3 Insert the battery again and long press the system button at the same time, until the LED quickly starts flashing orange.
- 4 Release the system button.
- 5 Long press the system button again until the LED lights up green.
- 6 Release the system button to finish the procedure.

8.1.4 To reset the DHC Radiator Thermostat (UK)

- 1 Open the battery compartment by pulling the cover backwards and then down.
- 2 Remove the batteries.
- 3 Insert the batteries again and long press the system button at the same time until the LED quickly starts flashing orange.
- 4 Release the system button.
- 5 Long press the system button again until the LED lights up green.
- 6 Release the system button to finish the procedure.

8.1.5 To reset the DHC Room Sensor

- 1 Grab the sides of the electronic unit and pull it out of the clip-on frame.
- 2 Remove a battery.
- 3 Insert the battery again and long press the system button at the same time, until the LED quickly starts flashing orange.
- 4 Release the system button.
- 5 Long press the system button again until the LED lights up green.
- 6 Release the system button to finish the procedure.

8.1.6 To reset the DHC Room Thermostat — 1

- 1 Grab the sides of the electronic unit and pull it from the wall mounting plate.
- 2 Remove a battery.
- 3 Insert the battery again and long press the system button at the same time, until the LED quickly starts flashing orange.
- 4 Release the system button.
- 5 Long press the system button again until the LED lights up green.
- 6 Release the system button to finish the procedure.

8.1.7 To reset the DHC Room Thermostat — 2

- 1 Grab the sides of the electronic unit and pull it out of the clip-on frame.
- 2 Remove a battery.
- 3 Insert the battery again and long press the system button at the same time, until the LED quickly starts flashing orange.
- 4 Release the system button.
- 5 Long press the system button again until the LED lights up green.

- 6 Release the system button to finish the procedure.

8.1.8 To reset the DHC Basic IO Box

- 1 Long press the system button until the LED quickly starts flashing orange.
- 2 Release the system button.
- 3 Long press the system button again until the LED lights up green.
- 4 Release the system button to finish the procedure.

8.1.9 To reset the DHC Floor Heating Controller — 6 zones

- 1 Long press the system button until the LED quickly starts flashing orange.
- 2 Release the system button.
- 3 Long press the system button again until the LED lights up green.
- 4 Release the system button to finish the procedure.

8.1.10 To reset the DHC Multi IO Box

- 1 Long press the system button until the LED quickly starts flashing orange.
- 2 Release the system button.
- 3 Long press the system button again until the LED lights up green.
- 4 Release the system button to finish the procedure.

8.2 Unreachable accessories



INFORMATION

It is recommended to keep accessories nearby the DHC Access Point when adding them in the ONECTA app.

If any of the accessories seemingly does not respond to setting changes, but you are still seeing notifications in the ONECTA app, the accessory may be unreachable. When this happens, the accessory also appears as unreachable in the ONECTA app.

Example: You see that the setpoint or operation mode on the DHC Access Point Thermostat does not match what is displayed in the ONECTA app.

This situation may indicate a communication problem between the accessories. In most cases, the accessory in question cannot be reached by the DHC Access Point. It is possible that the accessory becomes unreachable only after it was placed at its intended location. To resolve this issue, attempt the following resolutions, in order:

- 1 On location, verify that all DHC accessories are at least 50 cm physically apart from one another.
- 2 If there are metal objects, enclosures, or other radio signalling devices that may interfere with the communication of the DHC accessory, try moving them away from the line of communication between the accessory and the DHC Access Point. Mounting the unreachable DHC accessory on a wall can potentially improve the connection, because of the orientation of the antennas.
- 3 Use the EQ3-RFA RF analyser to verify if the wireless signal of the DHC Access Point is strong enough (see "[RF analyser](#)" [▶ 6]). Use a second RF analyser to check the strength of the signal nearby the other accessory. If the signal is only slightly to weak, you can try the steps described in point 2 again. If this does

not resolve the issue and the signal is still too weak, follow the steps described in point 4.

- 4 Add a Pluggable switch and meter (HmIP-PSM) to the ONECTA app to extend the range of the DHC wireless network (see "1.4 About supported devices" [▶ 10]). Follow the normal procedure for adding the accessory as described in "2.3.1 To add DHC accessories to the ONECTA app" [▶ 29]. Then, place the HmIP-PSM in between the DHC Access Point and the desired location of the unreachable accessory. In the ONECTA app, enable the range extender function. Once you have enabled the RF range extender, the signal strength should be improved.

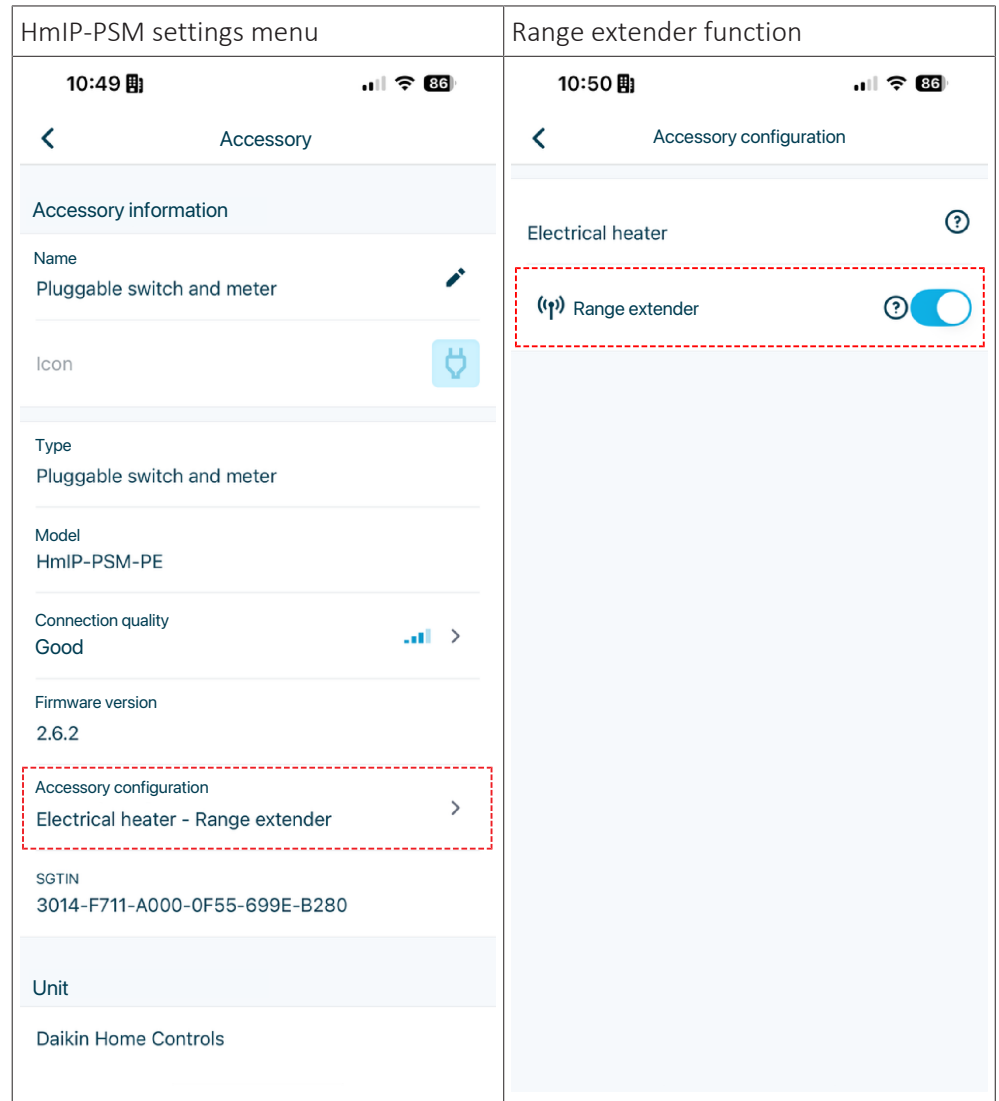

INFORMATION

To avoid communication problems, do NOT set up more than 2 HmIP-PSM as range extenders.

9 Wiring diagram

9.1 DHC Basic IO Box

Notes to go through before starting the unit

English	Translation
X*M	Field wiring terminal for AC
-----	Earth wiring
①	Several wiring possibilities
	Option
	Not mounted in switch box
	Wiring depending on model
	PCB

NOTES:

- 1 For applicable units see "5 Compatibility" [▶ 59].

LEGEND:

A2P	Printed circuit board (DHC Basic IO Box)
X*M	Terminal strip
See note ***	See note ***
Thermostat Main A	Thermostat Main A
Only for add zone	Only for add zone
Only for ***	Only for ***
Only for Control box	Only for Control box
OUT*	OUT*
BASIC IO BOX (TRV Only)	BASIC IO BOX (TRV Only)

Underfloor heating or combination of underfloor heating and radiator — Daikin Altherma 3

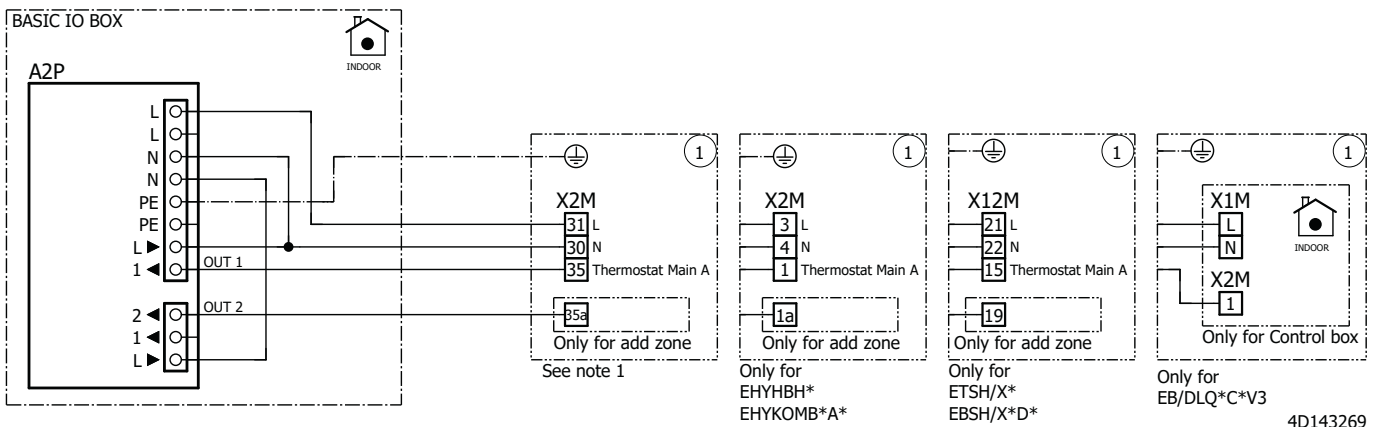

4D143269

Underfloor heating or combination of underfloor heating and radiator — Daikin Altherma 4

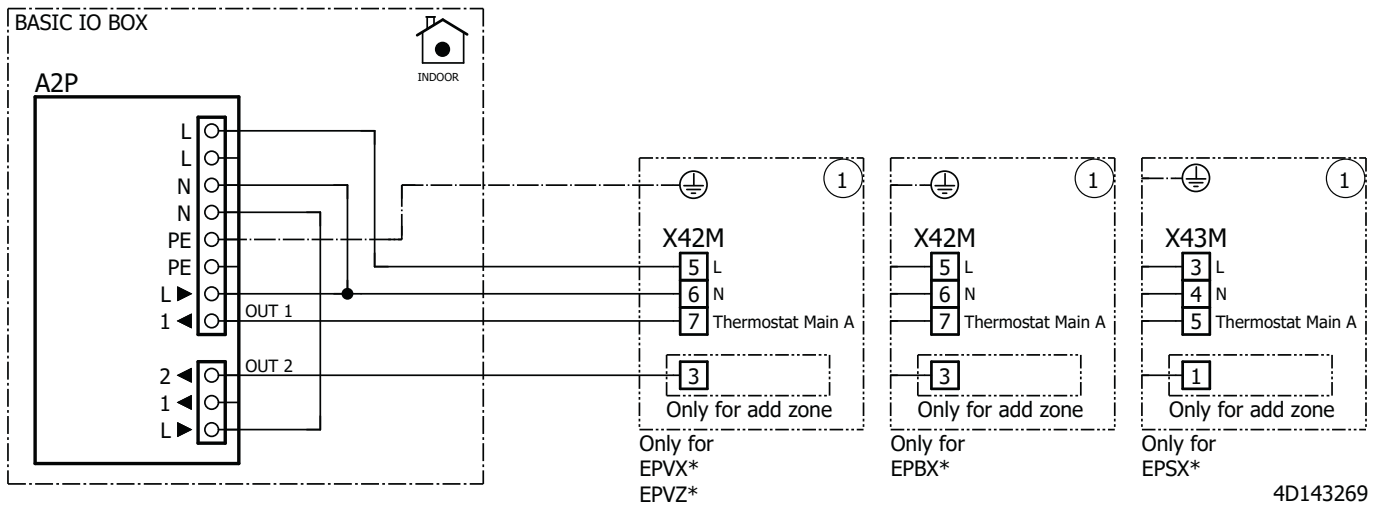

Radiator only — Daikin Altherma 3

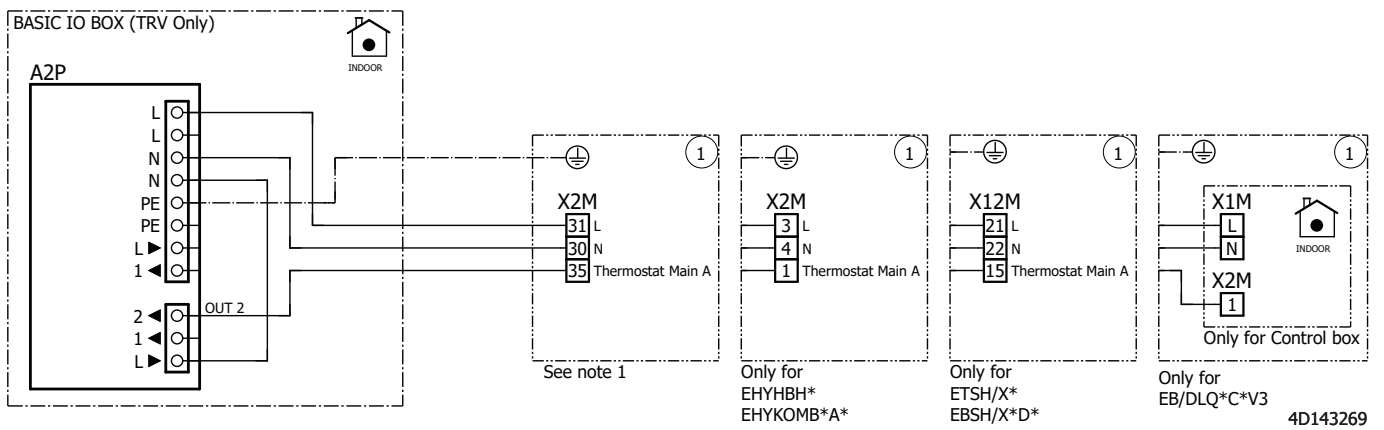

Radiator only — Daikin Altherma 4

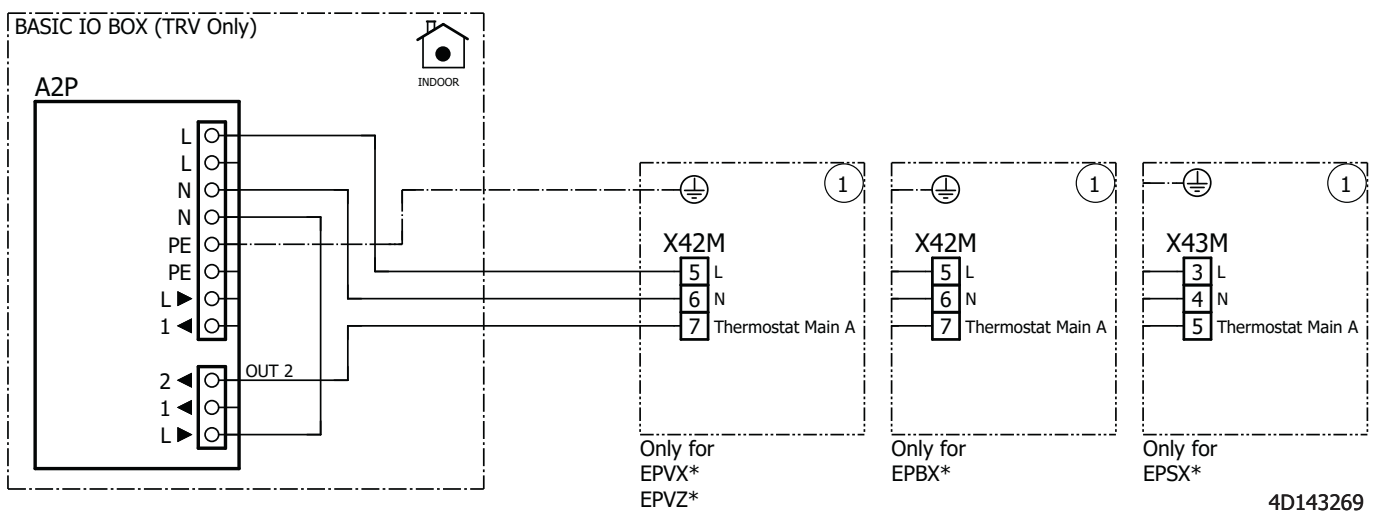

9.2 DHC Multi IO Box

Notes to go through before starting the unit

English	Translation
X*M	Field wiring terminal for AC
-----	Earth wiring
①	Several wiring possibilities
	Option
	Not mounted in switch box
	Wiring depending on model
	PCB

NOTES:

- 1 For applicable units see "5 Compatibility" [▶ 59].

LEGEND:

A2P	Printed circuit board (DHC Multi IO Box)
K1A	High voltage relay
X*M	Terminal strip
See note ***	See note ***
Thermostat Main A	Thermostat Main A
Only for add zone	Only for add zone
Only for ***	Only for ***
Only for Control box	Only for Control box
Cooling (K*R)	Cooling (K*R)
MULTI IO BOX (TRV Only)	MULTI IO BOX (TRV Only)

Underfloor heating or combination of underfloor heating and radiator — Daikin Altherma 3

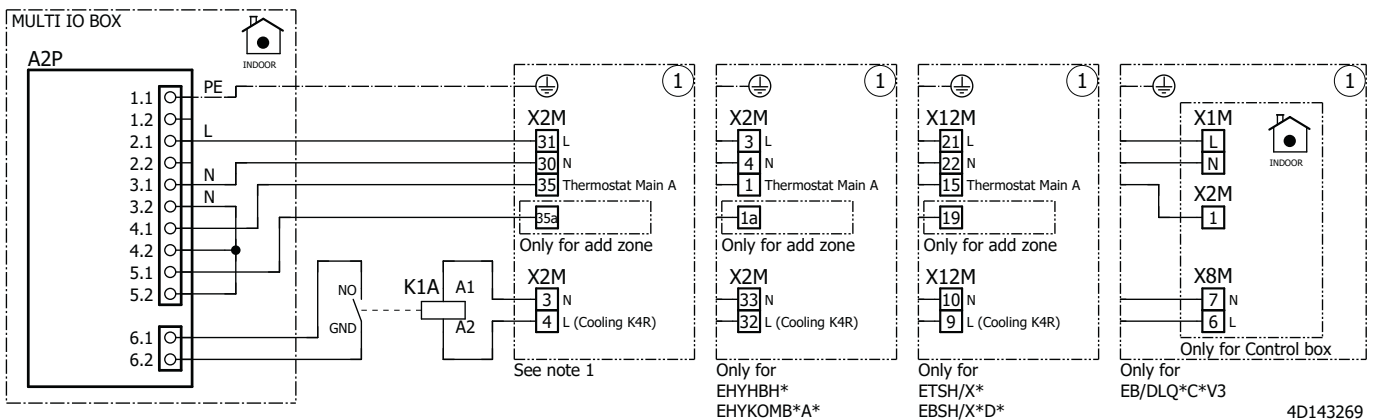

Underfloor heating or combination of underfloor heating and radiator — Daikin Altherma 4

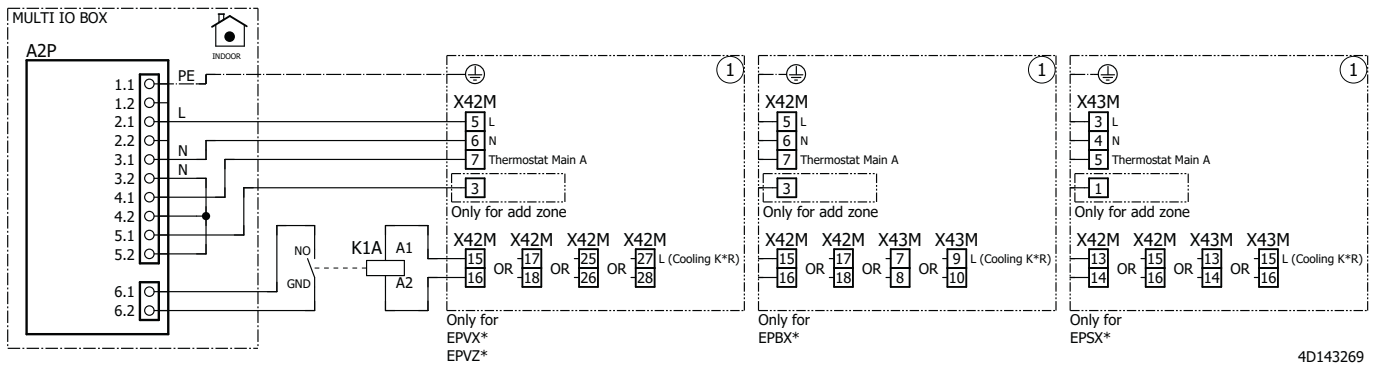

4D143269



INFORMATION

When connecting to terminals X42M or X43M on the indoor unit, you can choose which terminal pins to use. Since these are **Field IO** connections, you must tell the user interface on the indoor unit which terminal pins you used, so that it matches your system layout. For more information, see the installer reference guide of the Daikin Altherma unit.

Radiator only — Daikin Altherma 3

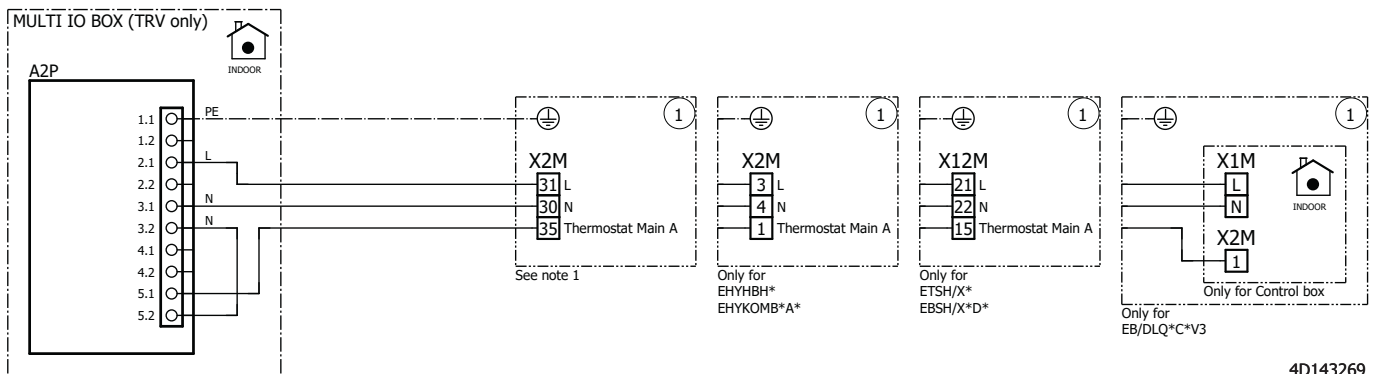

4D143269

Radiator only — Daikin Altherma 4

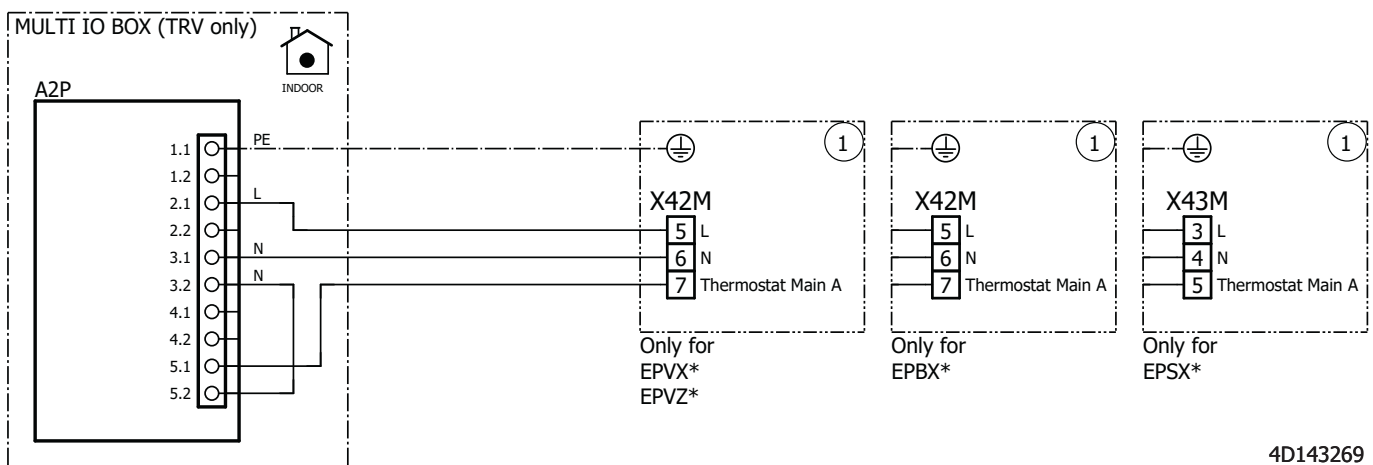

4D143269

9.3 DHC Multi IO Box with EKRK

Notes to go through before starting the unit

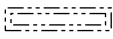
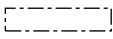
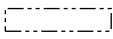
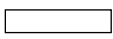
English	Translation
X*M	Field wiring terminal for AC
-----	Earth wiring
①	Several wiring possibilities
	Option
	Not mounted in switch box
	Wiring depending on model
	PCB

NOTES:

- 1 Configure as season input with no invert logic.
- 2 Configure as treatment input with no invert logic.

LEGEND:

A1P	Printed circuit board (floor cooling connection kit)
A2P	Printed circuit board (DHC Multi IO Box)
J*	Connector
M1P	Pump
M1S	2-way valve for dehumidifier
S1TDP	* Dew sensor (ON/OFF)
X*M	Terminal strip (hydro)
	* = Optional
Indoor Altherma unit	Indoor Altherma unit
Indoor dehumidifier	Indoor dehumidifier
Only for ***	Only for ***
NC valve	NC valve
Pump	Pump
Pump output	Pump output
Max. load	Max. load
4 A (inrush) - 230 V AC	4 A (inrush) – 230 V AC
1 A (continuous)	1 A (continuous)

Special application: Single zone reversible with dehumidifier

Daikin Altherma 3

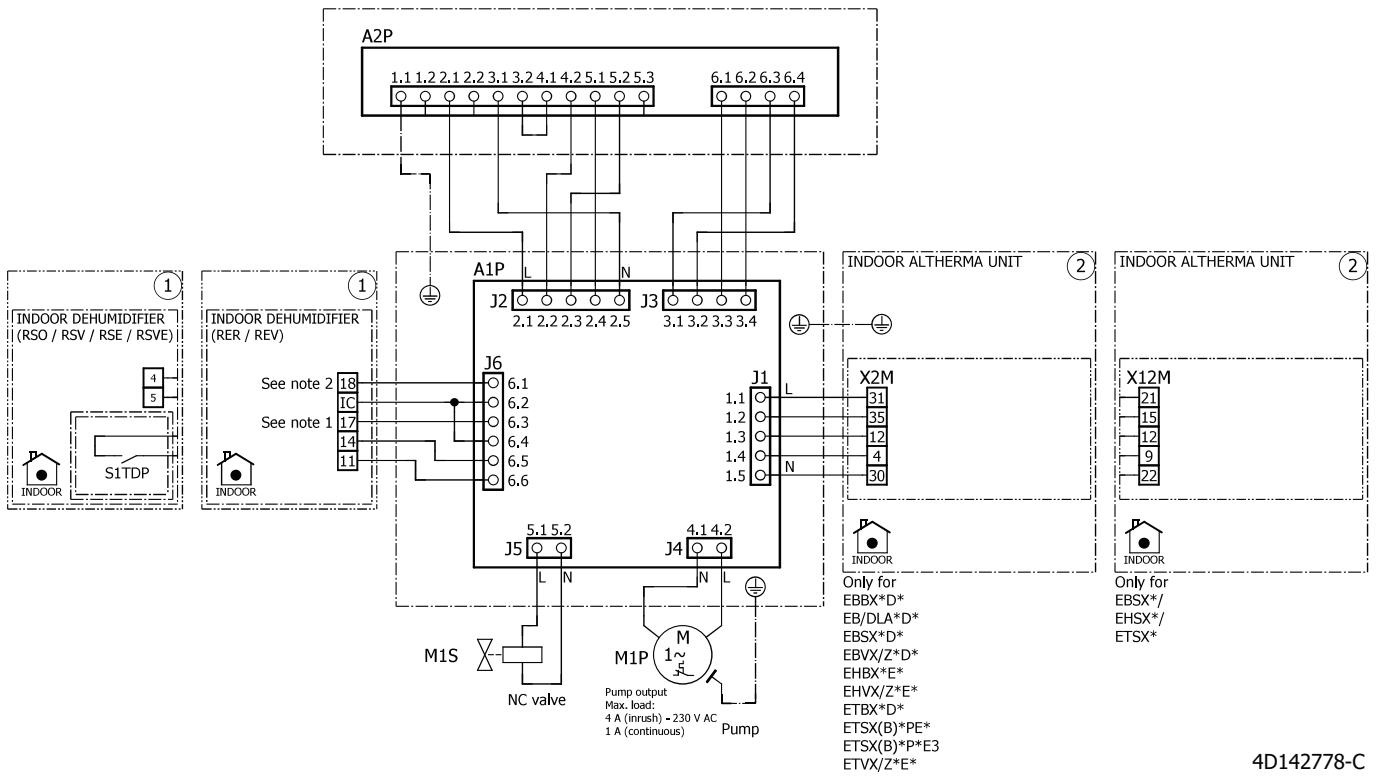

4D142778-C

Daikin Altherma 4

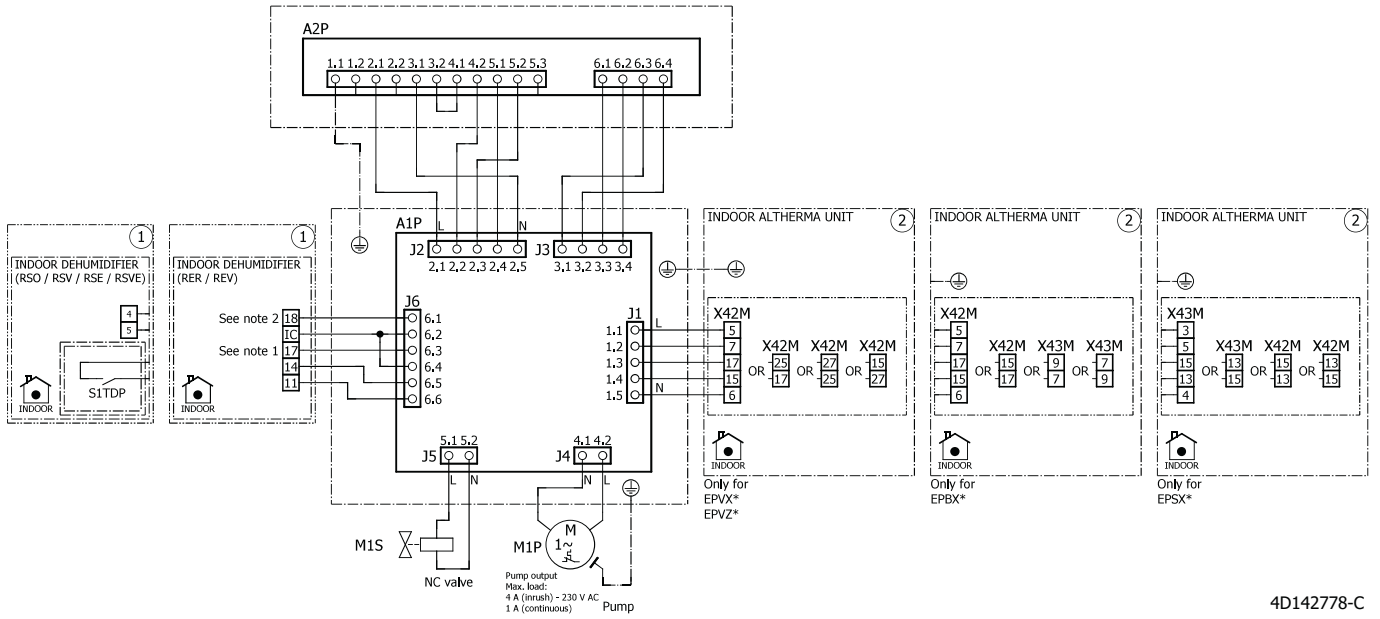

4D142778-C

10 Appendix

10.1 Guidelines when installing a DHC Floor Heating Controller

10.1.1 Basic requirements

Unit requirements still apply and need to be considered with all valves closed:

- Is the minimum water volume still valid?
- Is the minimum flow rate still valid?

These requirements need to be inspected first when you want to extend an existing installation with DHC support.

A bypass valve is mandatory when the application of the DHC Floor Heating Controller is considered. The recommended location for a bypass valve is close to the manifold.

10.1.2 About multi-zoning

The DHC Floor Heating Controller provides outputs to drive up to 9 valve actuators, divided into 6 heating zones ("HZ"). The heating zones to which the terminals for connecting the valve actuators belong to are marked on the controller itself.¹



INFORMATION

While HZ2, HZ4 and HZ6 each have 2 connectors for heating valves, it is recommended to only connect 1 valve to each heating zone.

Via the ONECTA app, you can allocate these heating zones to rooms. In case of underfloor heating, every room requires a DHC Room Thermostat to enable monitoring of the temperature and to configure a setpoint. You can allocate multiple connected heating zones to a single room, however, all connected heating zones should be allocated to a room.

When the DHC Room Thermostat registers a heat demand, it sends the requested setpoint and current temperature to the DHC Floor Heating Controller. The DHC Floor Heating Controller will then decide which valves of a heating zone should open and close to match the request. It can take **up to 15 minutes** for the DHC Floor Heating Controller to react to a new request.

Closing a valve will close the underfloor heating loop and takes the respective water circuit out of the available water volume.

Improving efficiency and optimising comfort

To improve efficiency of the system, it is recommended to spread the connections over the different heating zones as much as possible, instead of connecting multiple underfloor heating loops to a single zone. The control algorithm can work more efficiently when this is the case, resulting in improved end user comfort.

Example: A big open living room contains 6 separate underfloor heating loops that you want the DHC Floor Heating Controller to control.

⁽¹⁾ HZ1 is also marked on the controller as "Pump", but this can be ignored.

Preferred solution	Less optimised solution
<p>a DHC Floor Heating Controller terminals</p> <p>b Terminals for connecting heating valves of underfloor heating loops</p> <p>c Heating valves</p>	
<ul style="list-style-type: none"> A single underfloor heating loop is connected to each of the 6 heating zones. ONECTA room assignment: all 6 heating zones are assigned to a single room. 	<ul style="list-style-type: none"> All 6 underfloor heating loops are connected to only 4 of the 6 heating zones. ONECTA room assignment: the first 4 heating zones are assigned to a single room.

This principle is also applicable when you are using more than one the DHC Floor Heating Controller (when more than 9 valve actuators are required). In this case, it also important to spread the amount of used heating zones evenly across all Floor Heating Controllers.

Example: A home contains 10 separate underfloor heating loops that you want to control using two DHC Floor Heating Controllers. In both examples, every underfloor heating loop is connected to a single heating zone. In total, 10 heating zones are used.

Preferred solution	Less optimised solution
<p>a DHC Floor Heating Controller 1</p> <p>b DHC Floor Heating Controller 2</p> <p>c Terminals for connecting heating valves of underfloor heating loops</p> <p>d Heating valves</p>	
<p>The heating zones are spread evenly across 2 Floor Heating Controllers (5 heating zones each).</p>	<p>Only 4 heating zones are used on the second Floor Heating Controller, as opposed to 6 heating zones on the first Floor Heating Controller. The heating zones are not spread evenly across the 2 Floor Heating Controllers.</p>

10.1.3 About the use of a DHC Floor Heating Controller

**INFORMATION**

If there are only few heating zones requesting heating, the difference in temperature between the room temperature and the requested setpoint may be quite large before the system starts heating up. Over time, the system learns how to more efficiently heat up rooms, reducing this temperature difference over time. For better user comfort, spread the underfloor heating loops over the different heating zones as much as possible.

When is it useful to install a DHC Floor Heating Controller?

Application of the DHC Floor Heating Controller is useful if there are a few rooms with underfloor heating that have a different heat demand than the rest of the house:

- There are a few rooms with underfloor heating loops in the house with a reduced heat demand (for example unoccupied rooms, storage rooms, bedrooms, etc.). A reduced temperature in these rooms results in a smaller overall heat loss of the house, potentially saving energy.
- There are a few rooms with underfloor heating loops in the house with a particularly high heat demand (for example bathrooms, living room, etc.). This accessory allows it to reach higher temperatures in these rooms compared to others.

When is it NOT useful to install a DHC Floor Heating Controller?

If the desired temperature of each room in the house is more or less the same or on the same schedule, there is no need for zoning control.

A DHC Floor Heating Controller is also not recommended in case there is only one room with a particularly high heat demand:

- The minimum capacity of the unit is typically higher than the heat load of 1 room. The consequence is that it takes quite some time for the room to heat up, which is not energy efficient (ON/OFF operation because of minimum load condition).
- Due to the colder neighbouring rooms, a higher leaving water temperature setpoint is needed to reach the desired room temperature. This has a negative impact on the efficiency of the unit.

10.1.4 Technical specifications

Typical value of flow rate in 1 underfloor heating (UFH) loop: 1~2 l/min

- Typical value of Delta T in 1 UFH loop: 3~8°C
- Typical load of 1 UFH loop: $4.18 \text{ kJ/kgK} \times 2 \text{ l/min} \times 1/60 \text{ min/s} \times 5^\circ\text{C} = 0.7 \text{ kW}$

Sanity check based UFH load:

- Typical UFH output: 30~100 W/m²
- Typical surface covered by 1 UFH loop: 10~20 m²
- Typical load of 1 UFH loop: $65 \text{ W/m}^2 \times 15 \text{ m}^2 \approx 1 \text{ kW}$

Typical minimum capacity of heat pump $\approx \pm 3 \text{ kW}^{(1)}$

- Continuous operation requires 3~4 open UFH loops
- 3 UFH loops open: spurious ON/OFF operation expected
- 2 UFH loops open: not very frequent ON/OFF operation expected

⁽¹⁾ This minimum capacity will be different for higher capacity units. A useful rule of thumb is that the minimum capacity is roughly 30-40% of the published capacity table.

- 1 UFH loop open: frequent ON/OFF operation expected

Note: When the minimum volume and the minimum flow rate can be reached with all valves closed, there is no need to add a bypass valve to the system.

To guarantee that the minimum load corresponds with the minimum capacity of the unit, there are 2 options:

- 1 Keep a number of UFH loops uncontrolled (without valve actuators connected to the DHC Floor Heating Controller). The uncontrolled loops are only heated from the moment there is a heat demand from any of the controlled rooms. It is recommended to take the room that is large enough and is used most frequently.
- 2 The DHC Floor Heating Controller will always keep 2 heating zones active. Some heating zones offer 2 electrical outputs. If the heating zones with dual output are prioritised during allocation, the minimum capacity will be matched faster during a heat demand. In this case, 2 active heating zones will correspond with 3~4 UFH loops.

10.2 About non-connected solutions

Another way to use the DHC accessories is without internet connection. This type of configuration ONLY supports specific special applications, that make use of a direct wireless connection between the accessories and are NOT using a DHC Access Point. Without a DHC Access Point, these applications do NOT offer the convenience of the ONECTA app for configuration or monitoring.

It is possible to move to a connected ONECTA based system at a later time, but this will require the purchase of a DHC Access Point and a complete recommissioning.

If you do decide to add a DHC Access Point to your ecosystem at a later point in time, you will have to reset all accessories to factory settings. See "[8.1 Resetting to factory settings](#)" [▶ 68].

10.2.1 Single temperature water zone heating only unit with underfloor heating

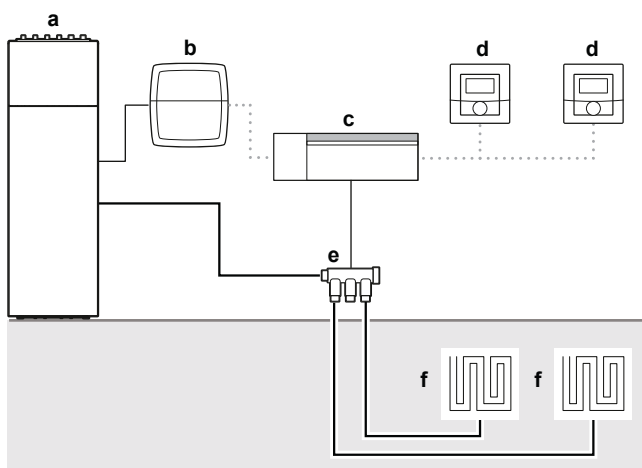

- a** Daikin Altherma (ext RT)
- b** DHC Basic IO Box
- c** DHC Floor Heating Controller
- d** DHC Room Thermostat — 2
- e** Collector
- f** Underfloor heating

To set up the configuration, you need to:

- 1 Connect the DHC Floor Heating Controller to the DHC Room Thermostat — 2,

- 2 Connect the DHC Floor Heating Controller to the DHC Basic IO Box, and
- 3 Configure the DHC Room Thermostat — 2.

To connect the DHC Floor Heating Controller to a DHC Room Thermostat — 2



INFORMATION

ALWAYS keep a minimum distance of 50 cm between the accessories.



INFORMATION

You can cancel the connecting procedure by briefly pressing the system button again. This will be indicated by the accessory LED lighting up red.



INFORMATION

If no connecting operations are carried out, connection mode is exited automatically after 3 minutes.

If you want to connect the DHC Floor Heating Controller to a DHC Room Thermostat — 2, the connection mode of both accessories has to be activated first. To do this, proceed as follows:

- 1 Press the select button briefly to select a channel. Press once for channel 1, twice for channel 2, etc.

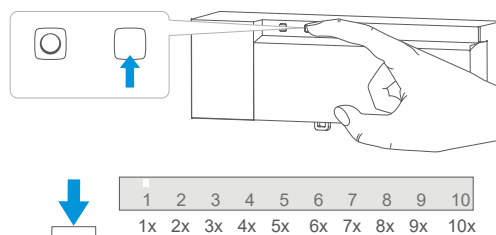

Result: The channel LED lights permanently for the corresponding channel.

- 2 Long press the system button of the DHC Floor Heating Controller until the LED quickly starts flashing orange.

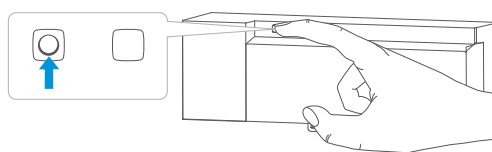

- 3 Long press the system button of the DHC Room Thermostat — 2 until the LED quickly starts flashing orange.

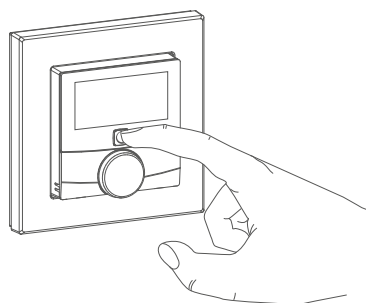

Result: If connecting was successful, the LED lights up green. If connecting failed, the LED lights up red. Try again.

To connect the DHC Floor Heating Controller to a DHC Basic IO Box



INFORMATION

ALWAYS keep a minimum distance of 50 cm between the accessories.



INFORMATION

You can cancel the connecting procedure by briefly pressing the system button again. This will be indicated by the accessory LED lighting up red.



INFORMATION

If no connecting operations are carried out, connection mode is exited automatically after 3 minutes.

If you want to connect the DHC Floor Heating Controller to a DHC Basic IO Box, the connection mode of both accessories has to be activated first. To do this, proceed as follows:

- 1 Press the select button of the DHC Floor Heating Controller briefly until the LEDs of all channels light up green.

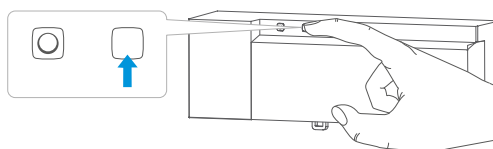

- 2 Long press the system button of the DHC Floor Heating Controller until the LED quickly starts flashing orange.

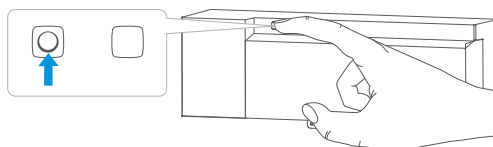

Result: Connection mode remains activated for 3 minutes.

- 3 Long press the system button of the DHC Basic IO Box until the LED quickly starts flashing orange.

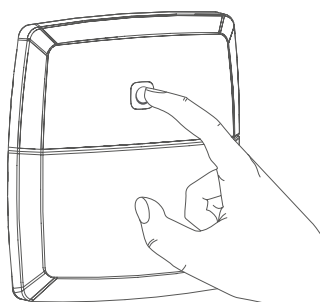

Result: If connecting was successful, the LED lights up green. If connecting failed, the LED lights up red. Try again.

Result: The DHC Basic IO Box is now configured to provide a THERMO ON/OFF to your Daikin Altherma unit.

10.2.2 Bizone unit with two independent water zones

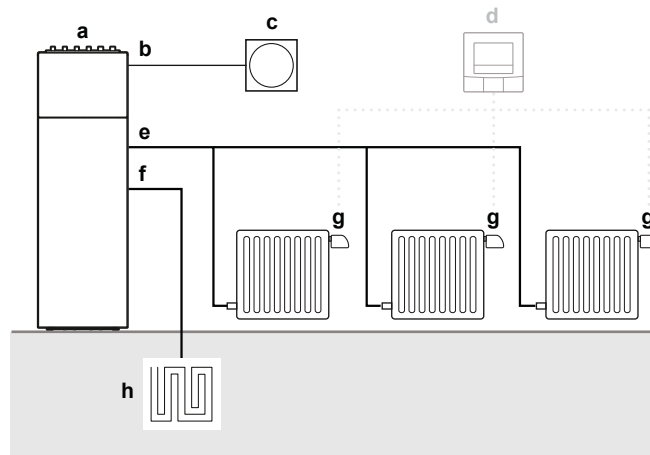

- a Daikin Altherma (LWT)
- b P1P2
- c Human Comfort Interface (BRC1HHDA)
- d (Optional) DHC Room Thermostat — 1
- e HT water zone
- f LT water zone
- g DHC Radiator Thermostat
- h Underfloor heating

**INFORMATION**

This configuration is based upon the Daikin Altherma unit operating on LWT instead of ext. RT.

The HT waterzone is equipped with radiators. Per radiator, a DHC Radiator Thermostat is added, which will regulate based upon the set temperature.

To set up the configuration, you need to:

- 1 Connect the DHC Radiator Thermostats,
- 2 (Optional) Add a DHC Room Thermostat — 1,
- 3 (Optional) Configure the DHC Room Thermostat — 1.

To connect the DHC Radiator Thermostats**INFORMATION**

ALWAYS keep a minimum distance of 50 cm between the accessories.

**INFORMATION**

You can cancel the connecting procedure by briefly pressing the system button again. This will be indicated by the accessory LED lighting up red.

**INFORMATION**

If no connecting operations are carried out, connection mode is exited automatically after 3 minutes.

**INFORMATION**

If you want to add another accessory to the existing ones, you first have to activate connection mode of the existing accessory and afterwards the connection mode of the new accessory.

You should connect all accessories in one room with each other. You can directly connect a DHC Radiator Thermostat to another DHC Radiator Thermostat. To do so, connection mode of both accessories has to be activated. To do this, proceed as follows:

- 1 Open the battery compartment by pulling it down.

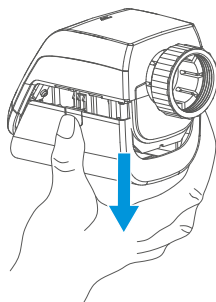

- 2 Remove the insulation strip from the battery compartment.
- 3 Long press the system button until the LED starts to flash orange.

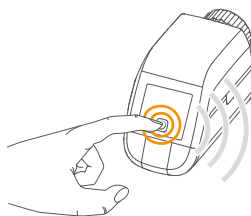

Result: Connection mode remains activated for 3 minutes.

- 4 Long press the system button of the accessory you want to connect until the LED starts to flash orange.

Result: If connecting was successful, the LED lights up green. If connecting failed, the LED lights up red. Try again.

To connect a DHC Room Thermostat — 1

It is possible to add a DHC Room Thermostat — 1 to a room. This provides a more efficient way to regulate the room temperature, because you can place the accessory where you want the temperature to be monitored.

To connect a DHC Room Thermostat — 1 to a DHC Radiator Thermostat, the connection mode of both accessories has to be activated. To do this, proceed as follows:

- 1 Open the battery compartment of the DHC Room Thermostat — 1 using a slotted screwdriver to loosen the wall mounting plate.

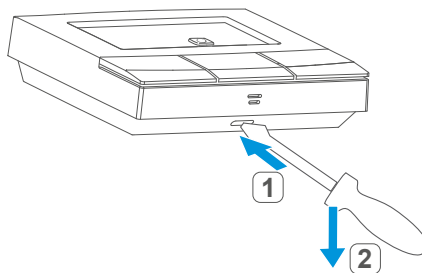

- 2 Remove the insulation strip from the battery compartment.

- 3 Long press the system button until the LED starts to flash orange.

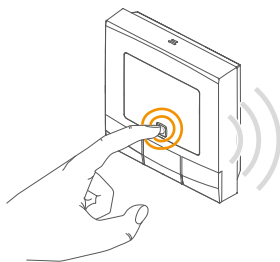

Result: Connection mode remains activated for 3 minutes.

- 4 Long press the system button of the accessory you want to connect until the LED starts to flash orange.

Result: If connecting was successful, the LED lights up green. If connecting failed, the LED lights up red. Try again.

User interface settings table

Daikin Altherma 3

Menu item	Mode	Description	Value
Main zone > Control	Installer mode ONLY	This setting defines that the unit will continuously produce water for space heating on the main zone.	Leaving water
Additional zone > Control		This setting defines that the unit will continuously produce water for space heating on the additional zone.	

Daikin Altherma 4



Menu item	Mode	Description	Value
[1.12] Main zone > Control	Installer mode ONLY	This setting defines that the unit will continuously produce water for space heating on the main zone.	Leaving water
[2.12] Additional zone > Control		This setting defines that the unit will continuously produce water for space heating on the additional zone.	

10.3 Configuration

10.3.1 DHC Room Thermostat — 1

When using the DHC Room Thermostat — 1 without the DHC Access Point, you can select the following modes via the configuration menu directly on the accessory and adjust the settings to your personal needs.

Display symbol	Modes and settings
AUTO	Automatic mode
MANU	Manual mode

Display symbol	Modes and settings
Offset	Offset temperature
Prg	Programming of schedules
	Operating lock
	Date and time
	Holiday mode



INFORMATION

Long press the menu button to go back to the previous level. The menu automatically closes without applying changes if there is no operation for more than 1 minute.

Automatic mode

In automatic mode, the temperature is controlled in accordance with the set schedule. Manual changes are activated until the next point at which the schedule changes. Afterwards, the defined schedule will be activated again.



INFORMATION

Switching from manual to automatic mode is **ONLY** possible if the date and time have been set.

Manual mode

In manual mode, the temperature is controlled in accordance with the current temperature set via the push buttons. The temperature remains activated until the next manual change.

Offset temperature

As the temperature is measured on the accessory itself, the temperature distribution can vary throughout a room. To adjust this, a temperature offset can be set. For example, if a temperature of 20°C is set but the room presents with **ONLY** 18°C, an offset of -2°C needs to be set.

Programming a schedule

You can create a schedule with 6 heating and cooling time slots (13 change settings) according to your personal needs.

Operating lock

Operation of the accessory can be locked to avoid settings being changed unintended (for example through involuntary touching).

Date and time

You can set the present date and time to be displayed on the accessory.

Holiday mode

In holiday mode, you can maintain a constant temperature for a certain period, for example during a holiday or a party.

To activate automatic mode

To activate the automatic mode, proceed as follows:

- 1 Long press the menu button to open the configuration menu.
- 2 Select **Auto** via the plus and minus buttons.
- 3 Confirm with the menu button.

Result: The symbol flashes twice and the accessory changes to automatic mode.

To activate manual mode

To activate the manual mode, proceed as follows:

- 1 Long press the menu button to open the configuration menu.
- 2 Select **Manu** via the plus and minus buttons.
- 3 Confirm with the menu button.

Result: The symbol flashes twice and the accessory changes to manual mode.

To adjust offset temperature

To adjust the offset temperature, proceed as follows:

- 1 Long press the menu button to open the configuration menu.
- 2 Select **Offset** via the plus and minus buttons.
- 3 Confirm with the menu button.
- 4 Select the desired offset temperature using the plus or minus button.
- 5 Confirm with the menu button.

Result: The temperature flashes twice and the accessory changes back to the standard display.

To program a schedule

To program a schedule, proceed as follows:

- 1 Long press the menu button to open the configuration menu.
- 2 Select **Prg** via the plus and minus buttons.
- 3 Confirm with the menu button.
- 4 In the menu item **dAy**, use the plus and minus buttons to select single days of the week, all weekdays, the weekend or the entire week for your heating schedule.
- 5 Confirm with the menu button.
- 6 Confirm the start time 00:00 with the menu button.
- 7 Select the desired temperature and start time using the plus and minus buttons.
- 8 Confirm with the menu button.

Result: The next time is shown in the display.

- 9 (Optional) Adjust the time via the plus and minus buttons.
- 10 Select the desired temperature for the next time period using the plus and minus buttons.
- 11 Confirm with the menu button.

12 Repeat this procedure until temperatures are stored for the entire period between 00:00 and 23:59.

Result: The time flashes twice and the accessory changes back to the standard display.

To activate or deactivate the operating lock

Activating the operating lock

To activate the operating lock, proceed as follows:

- 1** Long press the menu button to open the configuration menu.
- 2** Select **Operating lock** via the plus and minus buttons.
- 3** Confirm with the menu button.
- 4** Select **On** using the plus button to activate the operating lock.
- 5** Confirm with the menu button.

Result: On flashes twice and the accessory changes back to the standard display.

Result: After activating the operating lock, the lock symbol is shown in the display.

Deactivating the operating lock

To deactivate the operating lock, proceed as follows:

- 1** Long press the menu button to open the configuration menu.
- 2** Select **Operating lock** via the plus and minus buttons.
- 3** Confirm with the menu button.
- 4** Select **OFF** using the minus button to deactivate the operating lock.
- 5** Confirm with the menu button.

Result: OFF flashes twice and the accessory changes back to the standard display.

To set date and time

To set the date and time, proceed as follows:

- 1** Long press the menu button to open the configuration menu.
- 2** Select **Date/time** via the plus and minus buttons.
- 3** Confirm with the menu button.
- 4** Set the year, month, day, hour, and minutes using the plus or minus buttons and confirm.

Result: The time flashes twice and the accessory changes back to the standard display.

To activate holiday mode





To activate the holiday mode, proceed as follows:

- 1** Long press the menu button to open the configuration menu.
- 2** Select **Holiday** via the plus or minus buttons.
- 3** Confirm with the menu button.
- 4** Use the plus or minus buttons to select the time up to which you want to activate the holiday mode and confirm.
- 5** Select the date up to which you want to activate the holiday mode and confirm.
- 6** Select the temperature for the holiday mode and confirm.

Result: The symbol flashes twice and the accessory changes to holiday mode.

10.3.2 DHC Room Thermostat — 2

When using the DHC Room Thermostat — 2 without the DHC Access Point, you can select the following modes via the configuration menu directly on the accessory and adjust the settings to your personal needs.

Display symbol	Modes and settings
AUTO	Automatic mode
MANU	Manual mode
Offset	Offset temperature
Prg	Programming of schedules
	Operating lock
	Date and time
	Holiday mode
LCD	Selecting the desired temperature display
FAL	Configuring the DHC Floor Heating Controller
	Communication test

**INFORMATION**

Long press the control wheel to go back to the previous level. The menu automatically closes without applying changes if there is no operation for more than 1 minute.

Automatic mode

In automatic mode, the temperature is controlled in accordance with the set schedule. Manual changes are activated until the next point at which the schedule changes. Afterwards, the defined schedule will be activated again.

**INFORMATION**

Switching from manual to automatic mode is **ONLY** possible if the date and time have been set.

Manual mode

In manual mode, the temperature is controlled in accordance with the current temperature set via the control wheel. The temperature remains activated until the next manual change.

**INFORMATION**

You can fully close or open the valve by turning the control wheel as far as it will go in an anti-clockwise or clockwise direction. **OFF** or **On** is displayed.

Offset temperature

As the temperature is measured on the accessory itself, the temperature distribution can vary throughout a room. To adjust this, a temperature offset can be set. For example, if a temperature of 20°C is set but the room presents with ONLY 18°C, an offset of -2°C needs to be set.

Programming a schedule

You can create a schedule with up to 6 time slots (13 change settings) for each weekday separately, according to your personal needs.

▪ Heating or cooling

You can use your floor heating system to heat or cool rooms, provided your Daikin Altherma unit supports it.



INFORMATION

This configuration (Single temperature water zone heating only unit with underfloor heating) is heating ONLY, cooling is NOT possible.

▪ Optimum start/stop function

With the optimum start/stop you can reach the desired temperature in the room at the defined time.

▪ Week schedule numbers

You can select between the following 6 pre-configured schedules:

1 Pre-configured heating via radiator

Monday to Friday	Temperature
00:00 – 06:00	17.0°C
06:00 – 09:00	21.0°C
09:00 – 17:00	17.0°C
17:00 – 22:00	21.0°C
22:00 – 23:59	17.0°C

Saturday to Sunday	Temperature
00:00 – 06:00	17.0°C
06:00 – 22:00	21.0°C
22:00 – 23:59	17.0°C

2 Pre-configured heating via underfloor heating

Monday to Friday	Temperature
00:00 – 05:00	19.0°C
05:00 – 08:00	21.0°C
08:00 – 15:00	19.0°C
15:00 – 22:00	21.0°C
22:00 -23:59	19.0°C

Saturday to Sunday	Temperature
00:00 – 06:00	19.0°C
06:00 – 23:00	21.0°C

Saturday to Sunday	Temperature
23:00 – 23:59	19.0°C

3 Alternative heating schedule

Monday to Sunday	Temperature
00:00 – 06:00	17.0°C
06:00 – 22:00	21.0°C
22:00 – 23:59	17.0°C

4 Alternative cooling schedule 1

Monday to Friday	Temperature
00:00 – 06:00	17.0°C
06:00 – 09:00	21.0°C
09:00 – 17:00	17.0°C
17:00 – 22:00	21.0°C
22:00 – 23:59	17.0°C

Saturday to Sunday	Temperature
00:00 – 06:00	17.0°C
06:00 – 22:00	21.0°C
22:00 – 23:59	17.0°C

5 Pre-configured cooling via underfloor heating

Monday to Friday	Temperature
00:00 – 05:00	23.0°C
05:00 – 08:00	21.0°C
08:00 – 15:00	23.0°C
15:00 – 22:00	21.0°C
22:00 -23:59	23.0°C

Saturday to Sunday	Temperature
00:00 – 06:00	23.0°C
06:00 – 22:00	21.0°C
22:00 – 23:59	23.0°C

6 Alternative cooling schedule 2

Monday to Sunday	Temperature
00:00 – 06:00	17.0°C
06:00 – 22:00	21.0°C
22:00 – 23:59	17.0°C



INFORMATION

This configuration (Single temperature water zone heating only unit with underfloor heating) is heating ONLY, cooling is NOT possible.

Operating lock

Operation of the accessory can be locked to avoid settings being changed unintended (for example through involuntary touching).

Date and time

You can set the present date and time to be displayed on the accessory.

Holiday mode

In holiday mode, you can maintain a constant temperature for a certain period, for example during a holiday or a party.

Selecting the desired temperature display

You can choose which temperature will be displayed on the accessory. There are 3 options:

- Display the actual temperature,
- Display the setpoint temperature, or
- Display the actual temperature and humidity alternately.

Configuring the DHC Floor Heating Controller

You can configure your DHC Floor Heating Controller via the DHC Room Thermostat.

Communication test

You can check the connection between your DHC Room Thermostat and the DHC Floor Heating Controller.

To activate automatic mode

To activate the automatic mode, proceed as follows:

- 1 Long press the control wheel to open the configuration menu.
- 2 Select **Auto** by turning the control wheel.
- 3 Press the control wheel briefly to confirm.

To activate manual mode

To activate the manual mode, proceed as follows:

- 1 Long press the control wheel to open the configuration menu.
- 2 Select **Manu** by turning the control wheel.
- 3 Press the control wheel briefly to confirm.
- 4 Turn the control wheel to set the desired temperature.

To adjust offset temperature

To adjust the offset temperature, proceed as follows:

- 1 Long press the control wheel to open the configuration menu.
- 2 Select **Offset** by turning the control wheel.
- 3 Press the control wheel briefly to confirm.
- 4 Select the desired offset temperature using the control wheel.
- 5 Press the control wheel briefly to confirm.

To program a schedule

To program a schedule, proceed as follows:

- 1 Long press the control wheel to open the configuration menu.
- 2 Select **Prg** by turning the control wheel.
- 3 Press the control wheel briefly to confirm.
- 4 Turn the control wheel and select:
 - **type** for switching between heating (**HEAT**) or cooling (**COOL**),
 - **Pr.nr** to set the week schedule number (**no. 1, no. 2, ... no. 6**),
 - **Pr.Ad** for individual settings of the week schedule,
 - **OSSF** for activating (**On**) or deactivating (**OFF**) the optimum start/stop function.



INFORMATION

This configuration (Single temperature water zone heating only unit with underfloor heating) is heating ONLY, cooling is NOT possible.

To program a week schedule

To program a week schedule, proceed as follows:

- 1 Long press the control wheel to open the configuration menu.
- 2 Select **Prg** by turning the control wheel.
- 3 Press the control wheel briefly to confirm.
- 4 Select **Pr.Ad.** by turning the control wheel.
- 5 Press the control wheel briefly to confirm.
- 6 Select the required schedule by turning the control wheel.
- 7 Press the control wheel briefly to confirm.
- 8 In the menu item **dAy**, select single days of the week, all weekdays, the weekend or the entire week for your heating schedule.
- 9 Press the control wheel briefly to confirm.
- 10 Confirm the start time 00:00 with the control wheel.
- 11 Turn the control wheel to select the desired temperature for the start time.
- 12 Press the control wheel briefly to confirm.

Result: The next time is shown in the display. You can change this time using the control wheel.
- 13 Turn the control wheel to select the desired temperature for the next period.
- 14 Press the control wheel briefly to confirm.
- 15 Repeat this procedure until temperatures are set for the entire period between 00:00 and 23:59.

To activate or deactivate the operating lock

To activate or deactivate the operating lock, proceed as follows:

- 1 Long press the control wheel to open the configuration menu.
- 2 Select **Operating lock** by turning the control wheel.
- 3 Press the control wheel briefly to confirm.
- 4 Turn the control wheel to select **On** to activate the operating lock, or **OFF** to deactivate the operating lock.

To set date and time

To set the date and time, proceed as follows:

- 1 Long press the control wheel to open the configuration menu.
- 2 Select **Date/time** by turning the control wheel.
- 3 Set the year, month, day, hour and minutes by turning the control wheel.
- 4 Press the control wheel briefly to confirm.

To activate holiday mode

To activate the holiday mode, proceed as follows:

- 1 Long press the control wheel to open the configuration menu.
- 2 Select **Holiday** by turning the control wheel.
- 3 Press the control wheel briefly to confirm.
- 4 Turn the control wheel to select the start time and date (**S**), and confirm.
- 5 Turn the control wheel to select the end time and date (**E**), and confirm.
- 6 Turn the control wheel to set the temperature that you want to maintain during the defined time and confirm.
- 7 Turn the control wheel to select in which rooms you want to activate the holiday mode:
 - **OnE**: Holiday mode is activated for the current DHC Room Thermostat.
 - **ALL**: Holiday mode is activated for all DHC Room Thermostats that are connected to the DHC Floor Heating Controller.

To select the desired temperature display

- 1 Long press the control wheel to open the configuration menu.
- 2 Select **LCD** by turning the control wheel.
- 3 Press the control wheel briefly to confirm.
- 4 Turn the control wheel and select:
 - **ACT** to display the actual temperature,
 - **Set** to display the setpoint temperature,
 - **ACTH** for alternating between the actual temperature and humidity display.
- 5 Press the control wheel briefly to confirm.

To configure the DHC Floor Heating Controller

You can configure your DHC Floor Heating Controller via the DHC Room Thermostat — 2. Proceed as follows:

- 1 Long press the control wheel to open the configuration menu.
- 2 Select **FAL** by turning the control wheel.
- 3 Press the control wheel briefly to confirm.
- 4 (Optional) If the DHC Room Thermostat is connected to more than one DHC Floor Heating Controller, select the required one by using the control wheel.
- 5 Adjust the line-up, time/follow-up time, eco temperatures, intervals, etc.

To perform a communication test

To check the connection between your DHC Room Thermostat — 2 and the DHC Floor Heating Controller, proceed as follows:

- 1 Long press the control wheel to open the configuration menu.
- 2 Select **communication test** by turning the control wheel.

3 Press the control wheel briefly to confirm.

Result: Depending on the current status of the DHC Floor Heating Controller, the accessory is switched on or off for confirmation.

10.3.3 DHC Floor Heating Controller

The DHC Floor Heating Controller can ONLY be configured via the DHC Room Thermostat — 2. See "[To configure the DHC Floor Heating Controller](#)" [▶ 95].

10.4 Manual operation

10.4.1 DHC Room Thermostat — 1

After connecting and mounting, simple operations are available directly on the accessory.

- **Temperature:** Use the plus and minus buttons to change the temperature. In automatic mode, manual changes are activated until the next point at which the schedule changes. Afterwards, the defined schedule will be activated again. In manual mode, the temperature remains activated until the next manual change.
- **Boost function:** Press the boost button briefly to activate the boost function. The boost function will heat up the radiator quickly and shortly by opening the valve.

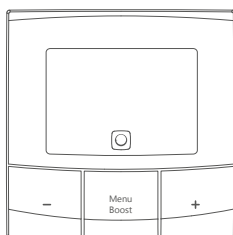

10.4.2 DHC Room Thermostat — 2

After configuration, simple operations are available directly on the accessory.



INFORMATION

If the DHC Room Thermostat is in standby mode, press the control wheel once to activate it.

- **Temperature:** Use the control wheel to change the temperature. In automatic mode, manual changes are activated until the next point at which the schedule changes. Afterwards, the defined schedule will be activated again. In manual mode, the temperature remains activated until the next manual change.
- **Boost function:** Press the control wheel briefly to activate the boost function. The boost function will heat up the radiator quickly and shortly by opening the valve.

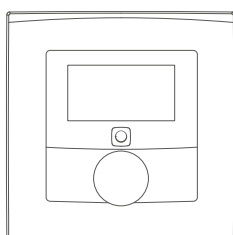

10.4.3 DHC Floor Heating Controller

After configuration, simple operations are available directly on the accessory.

To switch heating zones on or off

For installation and test purposes, you can manually switch single heating zones on or off. Proceed as follows:

- 1 Select the required channel by using the select button.
- 2 Press the select button until the LED flashes green 3 times.

Result: The channel will be switched on or off **for 15 minutes**. Afterwards, normal operation will be continued for the heating zone.

10.5 Loss of internet connectivity when using DHC Radiator Thermostat

The DHC Radiator Thermostat communicates to the DHC Access Point, which connects the accessory to the cloud. The ONECTA cloud transmits operating commands to the DHC Radiator Thermostat via the DHC Access Point.

The decision of whether a request for heat demand needs to be triggered is taken in the cloud. Whenever there is a loss of internet connectivity, this means it is not possible to guarantee the correct heat demand. If after 2 hours there is still no internet connection, the IO Box will trigger emergency operation. Depending on the time setting, the IO Box will:

- Not request any heat demand to the Daikin Altherma unit during summer time, in order to prevent using unnecessary energy.
- Request heat demand to the Daikin Altherma unit during winter time, as to ensure there is no loss of comfort.

Note that the DHC Floor Heating Controller does not need to communicate to the cloud, as it can communicate with the IO Box directly. This means that, when a loss of internet connectivity (more than 2 hours) were to occur in the situation as described in "[3.2.1 Bizone heating only](#)" [▶ 54], the underfloor heating demand is able to continue to function normally, even offline. At the same time, the radiator demand is triggered by emergency operation.

