

**DAIKIN**



# INSTALLATION MANUAL

## **Air-cooled condensing units**

ERAP110MBYNN  
ERAP150MBYNN  
ERAP170MBYNN



**CONTENTS**

	Page
Introduction.....	1
Technical specifications .....	1
Electrical specifications.....	1
Options and features.....	1
Operation range.....	2
Main components .....	2
Selection of location .....	2
Inspecting and handling the unit.....	2
Unpacking and placing the unit .....	2
Important information regarding the refrigerant used .....	3
Refrigerant circuit .....	3
Sizing and installation of the refrigerant circuit .....	3
Connecting the unit to the refrigerant circuit .....	3
Field wiring .....	3
Parts table.....	4
Power circuit and cable requirements .....	4
Connection of the air-cooled condensing unit power supply.....	4
Installation of the thermostat sensor (R4T).....	4
Interconnection cables .....	4
Cable for remote digital controller .....	4
Before starting .....	4
Customization in the service menu.....	5
How to continue .....	6

Thank you for purchasing this Daikin air conditioner.



READ THIS MANUAL ATTENTIVELY BEFORE STARTING UP THE UNIT. DO NOT THROW IT AWAY. KEEP IT IN YOUR FILES FOR FUTURE REFERENCE.

IMPROPER INSTALLATION OR ATTACHMENT OF EQUIPMENT OR ACCESSORIES COULD RESULT IN ELECTRIC SHOCK, SHORT-CIRCUIT, LEAKS, FIRE OR OTHER DAMAGE TO THE EQUIPMENT. BE SURE ONLY TO USE ACCESSORIES MADE BY DAIKIN WHICH ARE SPECIFICALLY DESIGNED FOR USE WITH THE EQUIPMENT AND HAVE THEM INSTALLED BY A PROFESSIONAL.

IF UNSURE OF INSTALLATION PROCEDURES OR USE, ALWAYS CONTACT YOUR DAIKIN DEALER FOR ADVICE AND INFORMATION.

**INTRODUCTION**

The Daikin ERAP110~170MBYNN air-cooled condensing units are designed for outdoor installation and used for cooling applications only. The units are available in 3 standard sizes with nominal cooling capacities of 100, 135 and 160 kW.

The present installation manual describes the procedures for unpacking, installing and connecting the ERAP units.

**Technical specifications<sup>(1)</sup>**

Model ERAP	110	150	170
<b>Dimensions HxWxD</b> (mm)	2160x2340x2238		
<b>Weight</b> (kg)	1326	1440	1516
<b>Connections:</b>			
- liquid line (inch)	7/8"		
- suction line (mm)	2-1/8"		
- pressure relief valve outlet (inch)	FNPT 1"		

**Electrical specifications<sup>(1)</sup>**

Model ERAP	110	150	170
<b>Power circuit</b>			
- Phase	3~		
- Frequency (Hz)	50		
- Voltage (V)	400		
- Voltage tolerance (%)	±10		

**Options and features<sup>(1)</sup>**

**Options**

- Suction stop valve
- Ampere and voltmeter
- Main isolator switch
- Dual pressure relief valve on the condenser
- Low noise operation
- Condenser protection grills
- BMS Connection (MODBUS/J-BUS, BACNET, LON)

**Features**

- Stepless capacity control (30%~100%)
- Low ambient operation (−15°C)
- Liquid line solenoid valve
- Voltage free contacts
  - general operation/pump or fan contact
  - alarm
  - operation circuit
- Changeable voltage free contacts
  - 100% unit signal
  - second evaporator pump
- Remote input
  - interlock contacts for e.g. water or airflow
- Changeable remote inputs
  - remote start/stop
  - enable/disable capacity limitation<sup>(2)</sup>
- Multiple language selection
- Schedule timer

(1) Refer to the operation manual or engineering data book for the complete list of specifications, options and features.

(2) Can be used for night set back and/or peak power limitation: A kWh-gauge is connected to a voltage free contact. If the contact is enabled, the circuit will be limited to a preset capacity step.

## OPERATION RANGE

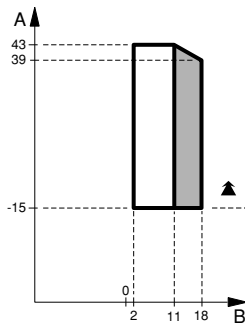

- A Outdoor temperature (°C DB)  
 B Evaporating temperature (°C) (Suction dew point)

- Standard operation range  
 Standard  
 Range for pull down operation

## MAIN COMPONENTS (refer to the outlook diagram supplied with the unit)

- 1 Condenser
- 2 Compressor 1 (M1C) with pressure relief valve
- 3 Discharge stopvalve
- 4 Liquid stopvalve
- 5 Suction stopvalve
- 6 Suction line
- 7 Liquid line
- 8 Drier + charge valve
- 9 Power supply intake
- 10 Emergency stop (S5E)
- 11 Switchbox
- 12 Digital display controller
- 13 Transportbeam
- 14 Ambient temperature sensor (R5T)
- 15 Field wiring intake
- 16 Main isolator switch (optional - S13S)

## SELECTION OF LOCATION

This is a class A product. In a domestic environment this product may cause radio interference in which case the user may be required to take adequate measures.

The units are designed either for roof mounting or ground level mounting and should be installed in a location that meets the following requirements:

- 1 The foundation is strong enough to support the weight of the unit and the floor is flat to prevent vibration and noise generation.
- 2 The space around the unit is adequate for servicing and the minimum space for air inlet and air outlet (refer to the operation manual) is available.
- 3 There is no danger of fire due to leakage of inflammable gas.
- 4 Select the location of the unit in such a way that neither the discharged air nor the sound generated by the unit disturb anyone.
- 5 Make sure that the air inlet and outlet of the unit are not positioned towards the main wind direction. Frontal wind will disturb the operation of the unit. If necessary, use a windscreen to block the wind.

## INSPECTING AND HANDLING THE UNIT

At delivery, the unit should be checked and any damage should be reported immediately to the carrier claims agent.

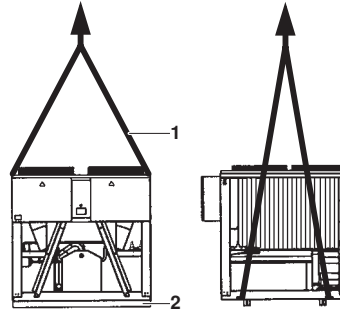

When handling the unit, take into account the following:

- 1 Lift the unit preferably with a crane and belts in accordance with the instructions on the unit. The length of the ropes (1) to be used for lifting are 6 m minimum each.
- 2 The unit is shipped with wooden beams (2) under it, these have to be removed before installation.

**NOTE** Try to reduce the drilling in the unit to a minimum. If drilling is inevitable, remove the iron filling thoroughly in order to prevent surface rust!

## UNPACKING AND PLACING THE UNIT

- 1 Remove the wooden beams from the unit.
- 2 Install vibration mountings in case of a roofmounted unit or other installation where noise and vibration might be an impediment.
- 3 Set the unit on a solid and level foundation.

Roof mounted:	The unit should be installed on steelchannel or I-beam frame to support the unit on the roof, or it can be installed on a concrete base.
Ground level mounted:	The unit should be installed on a solid base. It is recommended to fix the unit on a concrete base with anchor bolts.

Ground level mounting:

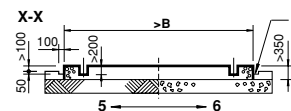
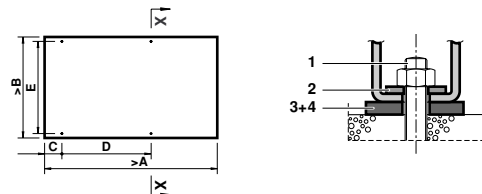

- The concrete foundation should approximately be 100 mm higher than the floor level for ease of plumbing work and better drain.

Model	Anchor bolt					size	Qty
	A	B	C	D	E		
ERAP110	3000	2210	410	1215	2125	M16X200	4
ERAP150	3000	2210	410	1215	2125	M16X200	4
ERAP170	3000	2210	410	1215	2125	M16X200	4

- Make certain that the foundation surface is even and flat.
- Fix anchor bolts (1) into the concrete foundation.  
When finally fixing the unit by means of these anchor bolts, make sure that the washers for channel DIN434 (2), and both field supplied rubber plates (3) and field supplied raw cork or rubber sheets (4) for better vibration protection, are installed as indicated.

**NOTE**



- The measurement tabulated is based on the fact the base is made in the ground (5) or on a concrete floor (6). In case the base is made on a rigid floor, it is possible to include thickness of concrete floor in that of the base.
- Ingredient ratio of the concrete is: cement 1, sand 2 and gravel 3. Insert iron bars of Ø10 at every interval of 300 mm. The edge of the concrete base should be planed.

## IMPORTANT INFORMATION REGARDING THE REFRIGERANT USED

This product is factory charged with N2.

The refrigerant system will be charged with fluorinated greenhouse gases covered by the Kyoto Protocol. Do not vent gases into the atmosphere.

Refrigerant type: R407C  
GWP<sup>(1)</sup> value: 1652.5

<sup>(1)</sup> GWP = global warming potential

Please fill in with indelible ink,

- the total refrigerant charge

on the refrigerant charge label supplied with the product.

The filled out label must be adhered in the proximity of the product charging port (e.g. onto the inside of the service cover).

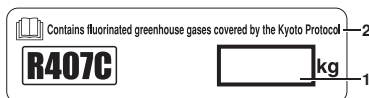

- 1 total refrigerant charge
- 2 Contains fluorinated greenhouse gases covered by the Kyoto Protocol

## REFRIGERANT CIRCUIT

### Sizing and installation of the refrigerant circuit

Installation of the refrigerant circuit should be done by a licensed technician and must comply with all relevant European and national regulations.

In order to minimize capacity loss, it is recommended to size the lines in such a way that the pressure drop of each line does not result in an evaporating temperature decrease of more than 1°C.

For this purpose we recommend that the equivalent length of the line should not exceed the following criteria:

Liquid piping: equivalent length (m)

	ERAP110	ERAP150	ERAP170
7/8"	34	17	13
1"	50	34	25
1-1/8"	100	100	50

Suction piping: equivalent length (m)

	ERAP110	ERAP150	ERAP170
2-1/8"	25	17	13
2-1/2"	50	34	25
2-5/8"	100	50	34

Equivalent length=measured length of the piping+A×number of elbows.

- A=0.5/m elbow for liquid piping
- A=1.5/m elbow for suction piping

**NOTE**



To assure oil return to the compressor do not use piping size above 2-1/8" for ERAP110 units or above 2-5/8" for ERAP150 and ERAP170 units for suction in the upward direction! If necessary, use double suction riser constructions.

**NOTE**



Make sure to install a sightglass in the liquid line as close as possible to the expansion device of the evaporator.

### Connecting the unit to the refrigerant circuit

Cut the spinned tube pipes (a nitrogen holding charge will escape) and connect immediately to the refrigerant circuit. Start vacuuming immediately after connection.

Never leave the condensing unit 'open' for longer time since the compressor oil is highly hygroscopic and will contaminate immediately when exposed to air!

Open the liquid stop valve, discharge stop valve and suction valve (if provided). Vacuum the unit and perform a leak test.

Precharge with following quantities of R407C refrigerant:

$$\text{Refrigerant charge [kg]} = \textcircled{1} + \textcircled{2} \times m^{\text{FL}} + \textcircled{3} \times m^{\text{FS}} + \textcircled{4} \times 0.5$$

①	ERAP110	ERAP150	ERAP170
kg	31	32	32
②	kg/m	③	kg/m
7/8"	0.33	2-1/8"	0.040
1"	0.45	2-1/2"	0.056
1-1/8"	0.58	2-5/8"	0.061

② = refrigerant weight per meter field liquid line (kg/m)

③ = refrigerant weight per meter field suction line (kg/m)

m<sup>FS</sup> = total length of the field suction line (m)

m<sup>FL</sup> = total length of the field liquid line (m)

④ = refrigerant volume of the field evaporator (dm<sup>3</sup>)

**NOTE**



After going through the checklist, start the machine and operate at a capacity not over 40% until the unit is fully charged.

For the final charge:

- Check if the sightglass remains bubble-free at 100% and at 70% load.
- Check if the subcool is >3°C and the superheat remains between 4°C and 10°C.
- Please fill out the final charge on the unit nameplate.

## FIELD WIRING

**NOTE**



All field wiring and components must be installed by a licensed electrician and must comply with relevant European and national regulations.

The field wiring must be carried out in accordance with the wiring diagram supplied with the unit and the instructions given below.

Be sure to use a dedicated power circuit. Never use a power supply shared by another appliance.

**NOTE**



Verify on the wiring diagram all electrical actions mentioned above, in order to understand the operation of the unit more deeply.

## Parts table

F1,2,3U	Main fuses for the unit
H1P	Indication lamp general operation
H2P	Indication lamp alarm
H3P	Indication lamp operation circuit
L1,2,3	Main terminals
PE	Main earth terminal
S6S	Changeable input 1
S9L	Contact that closes if the fan or pump is working
S10S	Changeable input 2
S11S	Changeable input 3
S12S	Changeable input 4
S13S	Main isolator switch
- -	Field wiring

## Power circuit and cable requirements

- The electrical power supply to the unit should be arranged so that it can be switched on or off independently of the electrical supply to other items of the plant and equipment in general.
- A power circuit must be provided for connection of the unit. This circuit must be protected with the required safety devices, i.e. a circuit breaker, a slow blow fuse on each phase and an earth leak detector. Recommended fuses are mentioned on the wiring diagram supplied with the unit.



Switch off the main isolator switch before making any connections (switch off the circuit breaker, remove or switch off the fuses).

## Connection of the air-cooled condensing unit power supply

- Using the appropriate cable, connect the power circuit to the L1, L2 and L3 terminals of the unit.  
In case the option "main isolator switch" is installed on the unit, the power circuit must be connected to the terminals 2, 4 and 6 of the main isolator switch.
- Connect the earth conductor (yellow/green) to the earthing terminal PE.

## Installation of the thermostat sensor (R4T)

The thermostat sensor is provided with a cable length of 12 m and can be found rolled up in the switchbox.

- In case of a water cooled evaporator, this sensor can be mounted in a sensor holder on the evaporator.
- In case of an air handling unit, this sensor can be mounted in a sensor holder in the air cooled evaporator water circuit.

Refer also to "Annex I" on page 6 for unit setup examples.

## Interconnection cables

- Be sure to interlock so, that the compressor will not come into operation unless the fan is operated. For this purpose 2 spare terminals are provided in the switch box. Refer to the wiring diagram supplied with the unit.
- Voltage free contacts  
The controller is provided with some voltage free contacts to indicate the status of the unit. These voltage free contacts can be wired as described on the wiring diagram. The maximum allowable current is 4 A.
- Remote inputs  
Besides the voltage free contacts, there are also possibilities to install remote inputs. They can be installed as shown on the wiring diagram.

## Cable for remote digital controller (See remote digital controller in the operation manual)

- A remote digital controller can be connected to the PCB inside the unit by means of a 6-ray cable and a connector located on the rear side of the remote digital controller in case you prefer to operate the unit from a distance. You are allowed to use a cable of up to 600 metres. Specifications of the cable: 6-ray telephone cable with a maximum cable resistance of 0.1  $\Omega$ /m.

- If you operate the digital controller from a distance with a cable as specified above, close the hole in the switch box cover with the supplied polycarbonate plate.

## Setting the addresses on the remote digital controller

When a remote digital controller is used, the address has to be set by means of DIP-switches according to the drawing below:

Remote digital controller address



## Where to find the DIP-switches of the remote digital controller

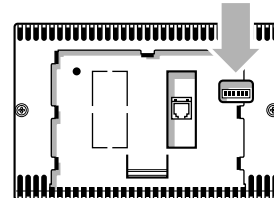

To avoid damage to the controllers liquid crystals during winter time, do not shut off the main power supply.

## BEFORE STARTING

### NOTE



After connecting the unit to the evaporating air unit, the unit should not be started, not even for a very short period of time, before the following pre-commissioning checklist is filled out completely.

tick ✓ when checked	standard steps to go through before starting the unit
<input type="checkbox"/>	<b>1</b> Check for <b>external damage</b> .
<input type="checkbox"/>	<b>2</b> Open all <b>shut-off valves</b> indicated by a red label: "OPEN THIS VALVE BEFORE OPERATION". (Open the liquid line, discharge and suction (if provided) stop valves completely.)
<input type="checkbox"/>	<b>3</b> Install <b>main fuses, earth leak detector and main switch</b> . Recommended fuses: aM according to IEC standard 269-2. <i>Refer to the wiring diagram for size.</i>
<input type="checkbox"/>	<b>4</b> Supply the main voltage and check if it is within the allowable $\pm 10\%$ limits of the nameplate rating. The electrical main <b>power supply</b> should be arranged so, that it can be switched on or off independently of the electrical supply to other items of the plant and equipment in general. <i>Refer to the wiring diagram, terminals L1, L2 and L3.</i>
<input type="checkbox"/>	<b>5</b> Connect the air- or waterflow contact, so that the unit can only come in operation when the fan or pump is running and the air-waterflow is sufficient.
<input type="checkbox"/>	<b>6</b> Check the <b>oil level</b> in the compressors.
<input type="checkbox"/>	<b>7</b> Connect the optional field wiring for <b>remote indication</b> .

### NOTE



- It is necessary to read the operation manual delivered with the unit before operating the unit. It will contribute to understand the operation of the unit and its electronic controller.
- Close all switch box doors after installation of the unit.

**I do confirm having executed and checked all the above mentioned items.**

Date

Sign

Keep for future reference.

## CUSTOMIZATION IN THE SERVICE MENU



All customized settings must be done by a licensed technician.

To change a setting in the service menu:

- 1 Enter the usersettings menu as indicated in the operation manual and press the  $\blacktriangledown$  key to go to the last screen to enter the service menu (this is only possible if the unit is off).
- 2 Enter the correct password using the  $\blacktriangledown$  and  $\blacktriangle$  keys. The password can be found in the service manual.
- 3 Press  $\blacktriangle$  to confirm the password and enter the service menu.
- 4 Go to the screen which contains the parameter to be modified by using the  $\blacktriangledown$  and  $\blacktriangle$  keys.
- 5 Position the cursor behind the parameter to be modified using the  $\blacktriangle$  key.
- 6 Select the appropriate setting using the  $\blacktriangledown$  and  $\blacktriangle$  keys.
- 7 Press  $\blacktriangle$  to confirm the modification. When the modification has been confirmed, the cursor switches to the next parameter which can now be configured.
- 8 Place the cursor in the top left corner of the screen when you are finished changing the parameters on this screen.
- 9 Repeat from instruction 4 onwards to modify other parameters.

### Setting of the minimum temperature

It is possible to change the minimum allowed temperature (MIN. OUTWATER) in the service menu.

In case of a water cooled evaporator:

- Make sure that sufficient glycol is added to the water system according to the table.
- Make sure that the low pressure safety is lowered according to the table.

	minimum outlet water (MIN. OUTWATER)			
	2°C	0°C	-5°C	-10°C
Weight of ethylene glycol (%)	10	20	30	40
Weight of propylene glycol (%)	15	25	35	40
Low pressure setting (bar)	1.3	1.1	0.6	0.2



Improper setting of the minimum outlet water temperature can result in severe damage of the equipment.

### Setting the password for safety reset

To avoid resetting of safeties by unqualified persons, the user password is asked by default when resetting a safety.

This password however can be changed to SERVICE PASSWORD or to NONE.

#### NOTE



Since inadequate resetting of safeties can damage the machine, it is advised to keep the default setting of USER PASSWORD.

## Defining of the changeable digital inputs and outputs

Besides locked digital inputs and outputs there are a number of changeable digital inputs and outputs of which the function can be chosen from several possibilities.

Possible functions for changeable digital inputs are:

- NONE: no function is appointed to the changeable digital input.
- STATUS: no function is appointed to the changeable digital input, but the input status can be read in the "input/output" menu.
- REMOTE ON/OFF: to remotely switch the unit on or off.
- DUAL SETPOINT: to switch between setpoints.
- CAP. LIM. 1/2/3/4: to limit the capacity of the unit to the entered values.

Possible functions for the changeable digital output are:

- NONE (OPEN): no function is appointed to the changeable digital output.
- 1 (CLOSED): no function is appointed to the changeable digital output, but the output is closed.
- 2ND EVAP PUMP: can be used to steer a second evaporator pump.
- 100% CAPACITY: indicates when the unit is working at 100%.

Possible configurations for the changeable analog input are:

- NONE: no function is appointed to the changeable analog input.
- SETP. SIGN. 0/1V:
- SETP. SIGN. 0/10V:
- SETP. SIGN. 0/20mA:
- SETP. SIGN. 4/20mA:

This allows the user to define a setpoint in function of an analog input as mentioned above. Refer to "Defining the setpoint signal setting" on page 5.

### Defining the setpoint signal setting

The setpoint signal is used to change the setpoint by an external analog input signal on the unit.

#### Example

in setpoints menu

```
→ >
  SETPOINT 1: 07.0°C
  SETPOINT 2: 07.0°C
```

in service menu

```
→ _÷ CHANG. INP/OUTPUTS
→ AI1: SETP. SIGN: 0/1V
→ MAX SETP. DIF: 5.0°C
```

**Remark:** MAX SETP. DIFF is only available when input SETP. SIGN (0/1V, 0/10V, 0/20mA or 4/20mA) is selected.

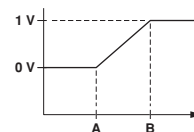

Result

A at 0 V → 12.0°C

B at 1 V → 12.0°C + 5.0°C = 17.0°C

Display in readout menu

SETPOINT 1: 12.0°C

SETPOINT 2: 17.0°C

### Steering the fan/pump manually

There is the possibility to turn the fan/pump on or off manually. This means that when the unit is off, the fan/pump can also be turned on at any time to check the pump.

## Defining the BMS settings

The BMS parameters allowing communication between the unit and the supervisory system can be modified with the **BMS SETTINGS** and the **BMSBOARD SETTINGS** screen of the service menu. The BMS parameters are:

**BMS SETTINGS** screen:

- **BMS CONTROL ALLOWED**: if set to Y (yes), the unit can be commanded and configured from a supervisory system. If set to N (no), the supervisory system can only read out values but cannot modify them.
- **BMS ADDR.PCB**: used to address the PCB.
- **PROTOCOL**: indicates the communication protocol. If the optional gateway is used to connect the units to a supervisory system, the protocol is CAREL.

**BMSBOARD SETTINGS** screen:

- **SER. BOARD**: indicates the type of serial connection. The default is set to RS485.
- **BAUD RATE**: indicates the speed of communication. The default setting of 19200 bps must be used when the optional gateway is connected.

## Defining the thermostat settings

Defining the thermostat settings for inlet and outlet water temperature of a, b and c can only be set in the service menu.

```

->STEPL SERVICE MENU
A:0.8 B:0.5 C:0.2°C
INLDIFF:0.5°C
    
```

To define the thermostat settings of the inlet and outlet water temperature.

## HOW TO CONTINUE

After installation and connection of the packaged air-cooled condensing unit, the complete system should be checked and tested as described in "Checks before initial start-up" in the operation manual supplied with the unit.

Fill out the brief operation instructions form and fix it visibly near the operating site of the refrigeration system.

## ANNEX I

- Connection to an air handling installation with face and bypass register for control of the air temperature.

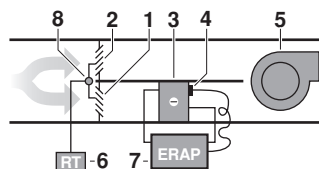

- 1 Face register
- 2 Bypass register
- 3 Air cooled evaporator
- 4 Thermostat sensor (R4T)
- 5 Fan
- 6 Room thermostat (RT)
- 7 ERAP unit
- 8 Servo motor for face/bypass registers

The thermostat sensor (R4T) delivered with the ERAP unit is to be mounted in a holder on the air cooled evaporator.

The ERAP unit will keep the cooling battery temperature to a constant value.

A field supplied room thermostat (RT) is controlling the face and bypass registers for control of the air temperature.

- Connection to an air handling installation with face and bypass register for control of the air temperature and the relative humidity.

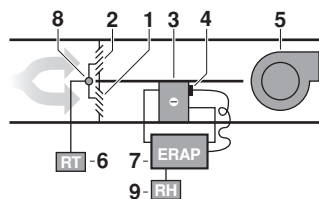

- 1 Face register
- 2 Bypass register
- 3 Air cooled evaporator
- 4 Thermostat sensor (R4T)
- 5 Fan
- 6 Room thermostat (RT)
- 7 ERAP unit
- 8 Servo motor for face/bypass registers
- 9 Relative humidity sensor (RH)

The thermostat sensor (R4T) delivered with the ERAP unit is to be mounted in a holder on the air cooled evaporator.

The setpoint for the temperature of the cooling battery will change depending on the relative humidity in the room. For this purpose, a relative humidity sensor (RH) with a 4~20 mA or 0~10 V output is connected to the ERAP unit. The setpoint is programmed in function of the relative humidity. (See also "Defining the setpoint signal setting" on page 5.)

A room thermostat (RT) is controlling the face and bypass registers for control of the air temperature.



# BRIEF OPERATION INSTRUCTIONS

## ERAP-MBYNN Air-cooled condensing units

Equipment supplier : \_\_\_\_\_

Service department : \_\_\_\_\_

.....  
 .....  
 .....

.....  
 .....  
 .....

Phone : .....

Phone : .....

### EQUIPMENT TECHNICAL DATA

Manufacturer	: DAIKIN EUROPE .....	Power supply (V/Ph/Hz/A)	: .....
Model	: .....	Maximum high pressure	: .....29 bar
Serial Number	: .....	Charging weight (kg) R407C	: .....
Year of construction	: .....		

### START-UP AND SHUT DOWN

- Start-up by switching on the circuit breaker of the power circuit. The operation of the water chiller is then controlled by the Digital Display Controller.
- Shut-down by switching off the controller and the circuit breaker of the power circuit.

**WARNINGS**

**Emergency shut down** : Switch off the **circuit breaker** located on .....

.....  
 .....

**Air inlet and outlet** : Always keep the air inlet and outlet free to obtain the maximum cooling capacity and to prevent damage to the installation.

**Refrigerant charge** : Use refrigerant R407C only.

**First aid** : In case of injuries or accidents immediately inform:



- **Company management** : **Phone** .....
- **Emergency physician** : **Phone** .....
- **Fire service** : **Phone** .....



